



**OPCW**

**Technical Secretariat**

---

S/2125/2023  
27 January 2023  
Original: ENGLISH

**NOTE BY THE TECHNICAL SECRETARIAT**

**THIRD REPORT BY THE OPCW INVESTIGATION AND IDENTIFICATION TEAM  
PURSUANT TO PARAGRAPH 10 OF DECISION C-SS-4/DEC.3  
“ADDRESSING THE THREAT FROM CHEMICAL WEAPONS USE”  
DOUMA (SYRIAN ARAB REPUBLIC) – 7 APRIL 2018**



## EXECUTIVE SUMMARY

1. The Director-General of the OPCW Technical Secretariat established the Investigation and Identification Team (IIT) pursuant to the Decision by the Conference of the States Parties entitled “Addressing the Threat from Chemical Weapons Use” (C-SS-4/DEC.3, dated 27 June 2018). The IIT began its work in June 2019, focusing on certain incidents for which the OPCW Fact-Finding Mission in Syria (FFM) had determined that use or likely use of chemical weapons on the territory of the Syrian Arab Republic occurred and for which the OPCW-United Nations Joint Investigative Mechanism had not reached a final conclusion.
2. The IIT is not a judicial body with the authority to assign individual criminal responsibility, nor does the IIT have the authority to make final findings of non-compliance with the Convention. The mandate of the IIT is to establish the facts.
3. This third report of the IIT sets out the findings of the investigations conducted in the period between January 2021 and December 2022, focusing on the incident in Douma, the Syrian Arab Republic, on 7 April 2018. On the basis of all the information obtained and its analysis, the IIT concludes that there are reasonable grounds to believe that, between 19:10 and 19:40 (UTC+3) on 7 April 2018, during a major military offensive aimed at regaining control of the city of Douma, at least one Mi-8/17 helicopter of the Syrian Arab Air Force, departing from Dumayr airbase and operating under the control of the Tiger Forces, dropped two yellow cylinders which hit two residential buildings in a central area of the city.
4. At Location 2,<sup>1</sup> the cylinder hit the rooftop floor of a three-storey residential building without fully penetrating it, ruptured, and rapidly released toxic gas—chlorine—in very high concentrations, which rapidly dispersed within the building, killing 43 named individuals and affecting dozens more.
5. At Location 4,<sup>1</sup> the cylinder hit the roof of a three-storey residential building (at the time uninhabited), and broke into the apartment below. The cylinder ruptured only partially, and started to slowly release chlorine, mildly affecting those who first arrived at the scene.
6. The IIT reached its conclusions on the basis of the degree of certainty of “reasonable grounds”, which is the standard of proof consistently adopted by international fact-finding bodies and commissions of inquiry. In reaching its conclusions, the IIT carefully assessed the information obtained from the FFM, States Parties, and other entities, coupled with interviews conducted by the IIT and analyses of samples, munition remnants, gas dispersion models, cylinder drop trials, computer modelling, satellite imagery, authenticated videos and photographs, as well as advice from experts, specialists, and forensic institutes, along with other relevant materials and sources. The IIT reviewed over 19,000 files, amounting to more than 1.86 terabytes, obtained and assessed 66 witness statements, five of which were from women, and considered data related to 70 samples. The IIT assessed this information holistically, scrutinising carefully its probative value through a widely shared methodology in compliance with best practices of international fact-finding bodies and commissions of inquiry. In so doing, the IIT adhered to applicable OPCW procedures, including with respect to chain of custody, supplemented as appropriate. The IIT thoroughly pursued lines of inquiry

---

<sup>1</sup> For the purposes of the present report, the IIT has adopted the same naming convention for the two locations of interest as that used in the relevant report of the FFM.

and scenarios suggested by the Syrian authorities and other States Parties, but was unable to obtain any concrete information supporting them. The conclusions in this report are based on the combination, consistency, and corroboration of all of the information gathered as a whole.

7. The challenges faced by the IIT included its inability to access the sites of the incident in the Syrian Arab Republic. The IIT regrets that this access was not granted, despite:
  - (a) various requests addressed by the Technical Secretariat to the authorities of the Syrian Arab Republic since the establishment of the IIT;
  - (b) the obligation by the Syrian Arab Republic to cooperate with the Technical Secretariat under paragraph 7 of Article VII of the Chemical Weapons Convention; and
  - (c) the obligation incumbent on the Syrian Arab Republic, pursuant to United Nations Security Council resolution 2118 (2013), to cooperate fully with the OPCW by providing personnel designated by the OPCW with immediate and unfettered access to any and all sites and individuals that the OPCW has grounds to believe to be of importance for the purpose of its mandate.

The IIT has expressed on several occasions its readiness to meet with representatives of the Syrian Arab Republic, at their convenience and at a location of their choosing, to discuss the progress of its activities and their modalities.

8. The Decision of 27 June 2018 by the Conference of the States Parties requires the Technical Secretariat to provide the reports on the IIT investigations to the OPCW Executive Council and to the United Nations Secretary-General for their consideration, and to preserve and provide information to the mechanism established by the United Nations General Assembly in resolution 71/248 (2016), as well as to any relevant investigatory entities established under the auspices of the United Nations. Accordingly, the IIT has endeavoured to compile this report and its related records and findings in a manner suitable for future use by these bodies. This also means that the IIT has carefully considered, in reaching its conclusions, that the information used in this report may be assessed and used by other bodies in the future.

S/2125/2023  
page 4

(blank page)



## TABLE OF CONTENTS

<b>EXECUTIVE SUMMARY</b> .....	<b>2</b>
<b>I. MANDATE</b> .....	<b>8</b>
<b>1. ESTABLISHMENT OF THE INVESTIGATION AND IDENTIFICATION TEAM</b> .....	<b>8</b>
<b>2. THE TASKS OF THE IIT</b> .....	<b>9</b>
<b>II. INVESTIGATIVE ACTIVITIES</b> .....	<b>10</b>
<b>3. APPROACH AND CHALLENGES IN THE INVESTIGATION</b> .....	<b>10</b>
<b>4. SCENARIOS</b> .....	<b>15</b>
<b>III. THE INCIDENT OF 7 APRIL 2018 IN DOUMA</b> .....	<b>16</b>
<b>5. BACKGROUND</b> .....	<b>16</b>
THE FINDINGS OF THE FACT-FINDING MISSION .....	16
GENERAL SITUATION IN THE AREA.....	17
<b>6. INCIDENT IN DOUMA, 7 APRIL 2018</b> .....	<b>20</b>
THE CONTEXT OF MILITARY ACTIVITIES IN THE AREA.....	20
METEOROLOGICAL CONDITIONS .....	24
CHEMICAL ANALYSES.....	25
Location 2 (“cylinder on the roof”) .....	30
Location 4 (“cylinder in the bedroom”).....	36
Assessment of “staging” hypotheses based on chemical data .....	38
SYMPTOMS OF AFFECTED PERSONS.....	40
Location 2 (“cylinder on the roof”) .....	41
Location 4 (“cylinder in the bedroom”).....	45
Investigation of alternative scenarios.....	45
Conclusions.....	46
ASSESSMENT OF REMNANTS.....	47
Location 2 (“cylinder on the roof”) .....	47
Location 4 (“cylinder in the bedroom”).....	61
Distinctive features of the cylinders, pattern of use, and possible scenarios .....	66
The cylinder found at the warehouse .....	71
Conclusions.....	73
ASSESSMENT OF THE IMPACT AND DELIVERY OF THE MUNITIONS .....	74
Preliminary observation of the scenes .....	75
Assessment of impact phenomena at Locations 2 and 4.....	79
Analysis of cylinders’ behaviour .....	83
Relevant properties of the cylinders .....	84
Review of FFM expert reports assessments.....	85
Implications for trajectories .....	87
Description of the simulation model.....	89
Trajectory results .....	89
Conclusions.....	95
Assessment of alternative delivery methods.....	96
THE ORIGIN OF THE CYLINDERS .....	103

<b>IV.</b>	<b>FACTUAL FINDINGS.....</b>	<b>109</b>
<b>7.</b>	<b>GENERAL REMARKS .....</b>	<b>109</b>
<b>8.</b>	<b>FACTUAL FINDINGS ON THE INCIDENT OF 7 APRIL 2018 .....</b>	<b>109</b>
<b>9.</b>	<b>GENERAL CONCLUDING OBSERVATIONS .....</b>	<b>118</b>
<b>10.</b>	<b>SUMMARY OF FACTUAL FINDINGS.....</b>	<b>119</b>

Annexes:

Annex 1:	INFORMATION MANAGEMENT AND OTHER INTERNAL PROCEDURES.....	121
Annex 2:	APPROACH TO OBTAINING AND SECURING INFORMATION.....	123
Annex 3:	SUMMARY OF CONTACTS WITH REPRESENTATIVES OF THE SYRIAN ARAB REPUBLIC AND OTHER STATES PARTIES RELEVANT TO THE CURRENT INVESTIGATIONS BY THE INVESTIGATION AND IDENTIFICATION TEAM.....	127
Annex 4:	REDACTED PARAGRAPHS.....	139

(blank page)

## I. MANDATE

### 1. ESTABLISHMENT OF THE INVESTIGATION AND IDENTIFICATION TEAM

- 1.1 This report is submitted pursuant to paragraph 10 of the decision adopted by the Conference of the States Parties (hereinafter “the Conference”) at its Fourth Special Session entitled “Addressing the Threat from Chemical Weapons Use” (C-SS-4/DEC.3, dated 27 June 2018) (hereinafter “the Decision of 27 June 2018”), and covers investigations conducted by the Investigation and Identification Team (IIT) in the period from January 2021 through December 2022.
- 1.2 In the Decision of 27 June 2018, the Conference recalled its own responsibility under paragraph 20 of Article VIII of the Chemical Weapons Convention (hereinafter “the Convention”) to oversee its implementation, to act in order to promote its object and purpose, and to review compliance with it.<sup>2</sup>
- 1.3 In paragraph 10 of the Decision of 27 June 2018, the Conference specifically decided that the Technical Secretariat (hereinafter “the Secretariat”):

shall put in place arrangements to identify the perpetrators of the use of chemical weapons in the Syrian Arab Republic by identifying and reporting on all information potentially relevant to the origin of those chemical weapons in those instances in which the OPCW Fact-Finding Mission in Syria [FFM] determines or has determined that use or likely use occurred, and cases for which the OPCW-UN Joint Investigative Mechanism [JIM] has not issued a report; and [...] that the Secretariat shall provide regular reports on its investigations to the [Executive] Council [of the OPCW] and to the United Nations Secretary-General for their consideration.

- 1.4 As stated in the “First Report by the OPCW Investigation and Identification Team Pursuant to Paragraph 10 of Decision C-SS-4/DEC.3 ‘Addressing the Threat from Chemical Weapons Use’, Ltamenah (Syrian Arab Republic), 24, 25, and 30 March 2017”, dated 8 April 2020 (S/1867/2020) (hereinafter “First IIT Report”), and consistent with the standards applied by international fact-finding missions and commissions of inquiry, the IIT’s mandate is to identify—on the basis of a sufficient and reliable body of information (i.e., the “reasonable grounds” standard)<sup>3</sup>—individuals, as well as entities, groups, and governments (i.e., non-State and State actors) directly or indirectly involved in the use of chemical weapons in the incidents within the scope of the IIT’s investigations.<sup>4</sup>

---

<sup>2</sup> See preambular para. 6 of C-SS-4/DEC.3.

<sup>3</sup> See First IIT Report, paras 2.17 to 2.20.

<sup>4</sup> See First IIT Report, paras 2.5 to 2.16.

## 2. THE TASKS OF THE IIT

- 2.1 The IIT is not a judicial body with the authority to assign individual criminal responsibility, nor does the IIT have the authority to make final findings of non-compliance with the Convention. The IIT is rather meant to facilitate the work of other mechanisms such as (a) primarily, the OPCW policy-making organs in their determinations of non-compliance and related consequences for a State Party in accordance with the Convention;<sup>5</sup> and (b) through the International, Impartial, and Independent Mechanism (IIIM), courts or tribunals, whether at the domestic, regional, or international level, having jurisdiction over the conduct investigated by the IIT. The IIT's support to the work of the latter is foreseen by the Decision of 27 June 2018, which specifically reaffirms the principle that "those responsible for the use of chemical weapons should be held accountable"<sup>6</sup> and stipulates that the Secretariat shall, inter alia, "provide information to the investigation mechanism established by the United Nations General Assembly in resolution 71/248 (2016)", (i.e. the IIIM)<sup>7</sup> "as well as to any relevant investigatory entities established under the auspices of the United Nations".<sup>8</sup>
- 2.2 The IIT aims at fulfilling these tasks by establishing the facts relevant to the identification of perpetrators of the use of chemical weapons in the incidents in the Syrian Arab Republic under its purview.
- 2.3 The factual findings of the IIT relate to the process of gathering, analysing, and reporting on facts relevant to the imputation of a specific human conduct to an individual or an entity. These factual findings are intrinsically different from legal findings, which instead relate to any wrongfulness of that conduct under the applicable legal framework and its legal consequences (i.e., liability).<sup>9</sup> The latter findings are not within the purview of the IIT. Notwithstanding, since the factual findings of the IIT may provide the initial grounds for further legal action, it is important for the IIT to adopt an information-gathering and review methodology which is consistent with future endeavours in this respect.
- 2.4 The IIT therefore endeavours to compile its records and factual findings in a manner suitable for future use by the OPCW policy-making organs, as well as the IIIM and any other relevant investigation body that may request material from the IIIM.

---

<sup>5</sup> See para. 11 of C-SS-4/DEC.3.

<sup>6</sup> See preambular para. 5 of C-SS-4/DEC.3.

<sup>7</sup> The IIIM has the primary mandate to "[...] consolidate, preserve and analyse evidence of violations of international humanitarian law and human rights violations and abuses and to prepare files in order to facilitate and expedite fair and independent criminal proceedings, in accordance with international law standards, in national, regional or international courts or tribunals that have or may in the future have jurisdiction over these crimes, in accordance with international law". See United Nations General Assembly resolution 71/248 (21 December 2016), para. 4.

<sup>8</sup> See para. 12 of C-SS-4/DEC.3.

<sup>9</sup> *Cf.*, for example, United Nations General Assembly resolution 46/59, Declaration on Fact-Finding by the United Nations in the Field of the Maintenance of International Peace and Security, UN Doc. A/RES/46/59 (9 December 1991), para. 17, which notes that the report of a fact-finding body "[...] should be limited to a presentation of findings of a factual nature". See also, among others, G. Arangio-Ruiz, *State Responsibility Revisited. The Factual Nature of the Attribution of Conduct to the State*, *Quaderni della Rivista di Diritto Internazionale* 6, Volume C-2017, pp. 3 and 110.

- 2.5 Details on the mandate and methods of work of the IIT can be found in the First IIT Report,<sup>10</sup> as well as in three Notes circulated by the Secretariat, respectively EC-91/S/3 (dated 28 June 2019),<sup>11</sup> EC-92/S/8 (dated 3 October 2019), and S/1918/2020 (dated 27 November 2020).

## II. INVESTIGATIVE ACTIVITIES

### 3. APPROACH AND CHALLENGES IN THE INVESTIGATION

- 3.1 Referring to the findings of the FFM as a starting point,<sup>12</sup> the IIT conducted an impartial, objective, and independent examination of all available information concerning the use of chemical weapons in the incident in the city of Douma (Syrian Arab Republic) on 7 April 2018, with a view to collecting, comparing, and analysing further information in order to identify the perpetrators, as described above. This incident is included in the list of incidents on which the IIT decided to focus its investigative work and which was made available to States Parties by the Secretariat in Annex 2 to Note EC-91/S/3. In selecting this incident from that list for further investigation, the IIT applied the criteria elaborated on in the First IIT Report concerning, inter alia: a) the severity of the incident; (b) the amount and apparent reliability of the information already available on the incident; and (c) the type of chemical substance(s) detected. The IIT also took into account patterns of similar incidents, and the reliability of persons who allegedly witnessed the events.<sup>13</sup>
- 3.2 The approach to the investigation of the incident in Douma of 7 April 2018 undertaken by the IIT is consistent with that described in both the First<sup>14</sup> and the Second IIT Reports.<sup>15</sup> In particular, the IIT conducted the following activities: (a) it analysed the information received from the FFM; (b) it requested information from States Parties, including the Syrian Arab Republic, and upon receipt reviewed this information; (c) it assessed the statements previously provided by witnesses and conducted interviews itself with persons of interest; (d) it obtained videos, documents, and other material from various sources; (e) it requested analytical data underlying the FFM Report, including data mining for specific chemicals from OPCW designated laboratories, as well as new analyses, and technical assessments from a number of forensic institutes and specialists; (f) it requested and analysed satellite imagery; (g) it collected information from open sources; and (h) it consulted experts. In carrying out these activities, the IIT relied on the same methods and procedures it had applied during the investigations described in the First IIT Report,<sup>16</sup> including with regard to (a) its

---

<sup>10</sup> See First IIT Report, paras 1.1 to 3.7 and Annexes 1 and 2 (and references therein).

<sup>11</sup> In the preparation of the present report, the composition of the IIT has included personnel from all five regional groups

<sup>12</sup> See “Report of the Fact-Finding Mission Regarding the Incident of Alleged Use of Toxic Chemicals as a Weapon in Douma, Syrian Arab Republic, on 7 April 2018” (S/1731/2019, dated 1 March 2019) (“FFM Report on Douma”), para. 2.17.

<sup>13</sup> See First IIT Report, paras 3.4 and 3.5.

<sup>14</sup> See First IIT Report, paras 4.1 to 4.10 and Annexes 1, 2, and 3 (and references therein).

<sup>15</sup> See Second IIT Report (S/1943/2021, dated 12 April 2021), paras 3.1 to 3.11 and Annexes 1, 2, and 3 (and references therein).

<sup>16</sup> See First IIT Report, paras 1.1 to 3.7 and Annexes 1 and 2 (and references therein), EC-91/S/3 and EC-92/S/8.

approach to obtaining and securing information (e.g., chain of custody, handling of information, security of witnesses, and sampling and analysis by designated laboratories); (b) its information and case management systems; and (c) the degree of certainty applied to the identification of perpetrators.

- 3.3 The IIT proceeded in a manner consistent with the Convention, relevant decisions of the policy-making organs,<sup>17</sup> and best practices of international fact-finding bodies and commissions of inquiry, especially when collecting information, such as witness statements, and assessing their relevance, sufficiency, and credibility, including by corroboration through separate sources.
- 3.4 As mentioned above, the collection of information in respect of the Douma incident of 7 April 2018 involved reaching out to States Parties, international and non-governmental organisations, and individuals, as well as a number of internationally reputable forensic institutes and experts and other relevant entities. Since the IIT is not judicially empowered to compel the submission of information and material, it relied, once again, on the voluntary cooperation of all these parties. In particular, regarding States Parties, the IIT expected them to provide access to relevant information and locations consistent with paragraph 7 of Article VII of the Convention.
- 3.5 Against this background, over the past months, the IIT has held several bilateral meetings with States Parties and other entities. It has also reviewed over 19,000 files, amounting to more than 1.86 terabytes; obtained and assessed statements from 66 witnesses, five of whom women; and requested and obtained analysis results and additional data for 70 samples related to this investigation.
- 3.6 In order to ensure the independence of its analysis, the IIT obtained examination results and technical assessments from a variety of experts and specialists from different nationalities and working at different institutions. In addition to the two designated laboratories used by the FFM for their analyses, the IIT reached out to a third designated laboratory and to a forensic institute for further studies, as well as to an independent expert in chemistry from yet another institution. Assessments of prevailing meteorological conditions were obtained from separate sources. A toxicologist with expertise in chemical incidents—but who had never before been involved in any assessment of this incident—was consulted to complement the analyses carried out by the FFM on the basis of the information obtained by the Secretariat, including two gas dispersion models developed independently from each other. Three munitions specialists (one of whom worked independently from the other two) provided their assessment on the cylinders considered by the IIT during its investigation. A terminal velocity expert and a missile trajectory expert, neither of whom had worked on the incident before, were consulted for the purpose of assessing the different hypotheses as to how the cylinders may have been delivered to, or placed at, the relevant locations in Douma. Almost 80,000 trajectories were simulated. To further support the experts' assessment, cylinder drop trials were independently commissioned to two specialised external institutions. A military affairs expert complemented the IIT's own internal analytical capacity. The IIT further engaged two specialists in geolocation and

---

<sup>17</sup> In addition to C-SS-4/DEC.3, see, the decision by the Conference entitled "Sampling and Analysis during Investigations of Alleged Use of Chemical Weapons" (C-I/DEC.47, dated 16 May 1997) which was applied *mutatis mutandis* by the IIT to its investigations. See Annex 2 below for details on these methodologies.

open-source research, as well as a separate forensic institute for the extraction and analysis of metadata to assist in verifying the authenticity and reliability of digital material, including videos and photographic material, obtained through various sources.

- 3.7 Overall, the IIT engaged a total of 10 experts and specialists from three different regions to ensure the highest degree of objectivity, impartiality, and independence of its investigation, the thorough corroboration of the information and evidence it gathered, and the overall solidity and consistency of its findings.
- 3.8 The IIT assessed the information obtained, including by corroboration through other sources, in order to determine its sufficiency, relevance, and reliability. With specific regard to videos and photographs, the IIT conducted or obtained forensic analyses aimed at verifying their authenticity through geolocation, metadata assessment, and other techniques. The IIT will provide this information to the IIIM as required by paragraph 12 of the Decision of 28 June 2018 and in accordance with applicable OPCW confidentiality rules and protocols.
- 3.9 During the investigation of the incident in Douma of 7 April 2018, the IIT encountered issues similar to those mentioned in the First<sup>18</sup> and Second<sup>19</sup> IIT Reports, especially with regard to (a) the lack of cooperation from the Syrian Arab Republic, namely its unwillingness to respond to the Secretariat's requests, as explained below; (b) the impossibility to access the site of the incident; (c) the lapse of time between the date of the incident and the IIT's investigation; and (d) the attendant difficulties in gathering additional information. In addition, the IIT, as an integral part of the Secretariat, has been faced with the impact of the outbreak of the COVID-19 pandemic on the implementation of the OPCW's activities and the mitigating measures that have been taken in response, as illustrated in the relevant Notes by the Secretariat.<sup>20</sup> However, while these mitigating measures limited the number of deployments in the initial phase of the investigations, they had no significant impact on the IIT's capacity to secure information and evidence in accordance with its methodology and standard of proof.
- 3.10 The IIT also faced a number of challenges specific to the incident under investigation. For instance, the IIT received reliable indications from different sources that persons with knowledge of the incident (including medical personnel, nurses, and first responders) were exposed to threats, coercion, intimidation, and other forms of pressure. The IIT notes that fear and pressures of this kind interfere with the flow of information to investigatory bodies such as the IIT. Nonetheless, the IIT did not rely on this circumstance to draw conclusions on the identification of perpetrators of the use of chemical weapons, but on factual findings only.
- 3.11 The IIT employed best practices aimed at ensuring the safety, security, and well-being of the persons with whom it interacted. This included protecting the privacy of individuals and using only information for which informed consent was provided. Whenever, in the course of the investigation into the incident and subject to a thorough

---

<sup>18</sup> See First IIT Report, paras 4.1 to 4.10.

<sup>19</sup> See Second IIT Report, paras 3.5 to 3.11.

<sup>20</sup> See, in particular: S/1863/2020 (dated 20 March 2020); S/1870/2020 (dated 17 April 2020); S/1876/2020 (dated 2 June 2020); S/1890/2020 (dated 26 August 2020); S/1918/2020; S/1930/2021 (dated 18 February 2021); S/1967/2021 (dated 5 July 2021); and S/1996/2021 (dated 5 October 2021). See also para. 7 of the report by the Director-General (EC-95/DG.15, dated 21 September 2020).



case-by-case risk assessment, the IIT had reasonable grounds to believe that a potential witness would be endangered as a result of their engagement with the IIT, it refrained from approaching them, in line with the “do-no-harm” principle, which is a key component of its methodology.

- 3.12 The IIT was also made aware that a number of sources with knowledge of the events had been evacuated from Douma in the immediate aftermath of the incident, and had to destroy or leave behind potential evidence owing to fear of being searched and retaliated against on the way out of Douma.
- 3.13 The IIT notes the significant number of official and unofficial statements, communications to OPCW and other international bodies, public events and meetings, media and social media reports and other open-source materials focusing on the 7 April 2018 attack on Douma. These include analyses, purported reports and assessments, and statements on particular aspects of the incident that appeared, at times, as attempts to spread disinformation and to undermine efforts to reach evidence-based findings on the dynamics of the incidents and its perpetrators.
- 3.14 In order to fulfil the mandate entrusted upon it by the Conference and to mitigate the impact of disinformation on its investigation, the IIT has strived to confine itself to the investigation and analysis of facts susceptible of corroboration only. To do so, it also secured the support of an open-source researcher in order to mine, select, authenticate, and corroborate available open sources on the incident. The IIT has also consulted a specialised forensic institute in order to ensure that the metadata of all the video and materials used for the purposes of the present report would be duly verified and authenticated, in line with best practices of digital forensics analysis.
- 3.15 Finally, the IIT notes Note Verbale No. 68 (dated 9 July 2021), in which the Syrian Arab Republic notified the OPCW of the destruction of “the two chlorine cylinders related to the alleged Douma incident of 2018”.<sup>21</sup> In an earlier communication submitted in the aftermath of the 7 April 2018 incident, the Syrian Arab Republic had informed the Secretariat that the cylinders had been moved and stored in a “secure location with a view to pursuing the investigations concerning those who have used the cylinders.”<sup>22</sup> While the IIT was able to access samples of remnants collected by the FFM at both relevant locations in Douma between 21 and 25 April 2018, the destruction of the cylinders has precluded any further assessment or analysis for the purposes of the present report. Furthermore, despite repeated requests, the outcome of the investigations referenced by the Syrian Arab Republic in its note verbale was never shared with the IIT.

---

<sup>21</sup> Permanent Mission of the Syrian Arab Republic to the OPCW, Note Verbale no. 68 to the Secretariat dated 9 July 2021.

<sup>22</sup> Syrian Arab Republic, Ministry of Foreign Affairs and Expatriates, National Authority for the Implementation of the Chemical Weapons Convention, Note Verbale No. 56 to the Secretariat (dated 3 May 2018).

- 3.16 Despite these constraints, the IIT was able to carry out its investigatory activities described above. The IIT considered it imperative to ensure the necessary degree of care during its gathering and assessment of the information, including consultations with experts in various disciplines.
- 3.17 In this context, on 22 December 2021, the Secretariat addressed a note verbale to the Permanent Representation of the Syrian Arab Republic to the OPCW, attaching a note by the IIT which invited the Syrian Arab Republic to, inter alia, submit any concrete information and sources or suggest additional avenues of inquiry in respect of the incident in Douma on 7 April 2018. The note further indicated the IIT's availability to meet with representatives of the Syrian Arab Republic at their convenience and at a location of their choosing. The purpose of this meeting would have been to discuss the progress of the investigation and the provision of other information, including access to locations, which the authorities of the Syrian Arab Republic may have been able to facilitate.
- 3.18 Copies of the above-mentioned Secretariat's note verbale and its attached notes from the IIT are enclosed in Annex 3 to this report. As at the date of this report, the Secretariat had not received a response from the Syrian Arab Republic to the requests set forth in that note verbale.
- 3.19 As pointed out in the attachment to the Secretariat's note verbale, the IIT took specific note of the position previously expressed by the Syrian Arab Republic on the incident in Douma of 7 April 2018, including relevant information it had submitted in some of its notes verbales to the Secretariat, in 2018 (in the aftermath of the incident), in 2019, and in 2021. The information presented by the Syrian Arab Republic in these notes verbales was therefore taken into account by the IIT when considering possible scenarios concerning the use of chemical weapons in Douma on 7 April 2018, and is further discussed in the following sections of this report.
- 3.20 The IIT also took into due consideration the position expressed at several stages by the Russian Federation on the incident in Douma. The information presented by the Russian Federation in notes verbales to the Secretariat and other official communications and statements (e.g. to the United Nations Security Council, to the Executive Council (hereinafter "the Council") and to the Conference) was also taken into account by the IIT in the course of its investigation when considering possible scenarios concerning the use of chemical weapons in Douma on 7 April 2018, as noted in subsequent sections of this report.
- 3.21 On 28 January 2022, the Secretariat addressed a note verbale to the Permanent Representation of the Russian Federation to the OPCW<sup>23</sup> requesting any concrete information which would have been potentially relevant to establishing the origin of the chemical weapons used in Douma on 7 April 2018 and useful to identify the perpetrators, including information related to actors that might have had the capabilities to develop, produce, stockpile, and use such weapons. On 15 February 2022, the Permanent Representation of the Russian Federation to the OPCW responded via note verbale to the Secretariat, reiterating its determination that Decision C-SS-4/DEC.3 had been adopted *ultra vires*, and that paragraph 7 of Article VII of the Convention was therefore not

---

<sup>23</sup>

NV/ODG-223/22, 28 January 2022.

applicable to any activities carried out by the Secretariat in connection with the aforementioned decision.<sup>24</sup> No further elaboration or supporting evidence was provided.

3.22 Nevertheless, the IIT was able to assess the explanations and some—albeit limited—information transmitted by the Syrian Arab Republic and the Russian Federation to the Secretariat regarding the incident under review since it occurred. No further elaboration or supporting evidence was provided by the Syrian or Russian authorities, notwithstanding the Secretariat’s requests and the correspondence addressed to those authorities.<sup>25</sup>

#### 4. SCENARIOS

4.1 In preparing its investigation plan for the incident in Douma on 7 April 2018, the IIT considered various hypotheses as to how the incident might have occurred, and then proceeded to develop concrete scenarios based on all available information. In doing so, the IIT took into account the positions presented by representatives of the Syrian Arab Republic and other States Parties, considering the challenges mentioned above.<sup>26</sup>

4.2 Among these scenarios, the IIT considered the views of the Syrian Arab Republic and of the Russian Federation that the incident had been “staged by terrorist armed groups” and the Syria Civil Defence (also known as the “White Helmets”) with the support of Western States, in order to forge accusations against the Syrian Arab Army.

4.3 The IIT specifically considered allegations that the “staging” of the incident had been carried out by, for example, fabricating videos portraying medical personnel and first responders pretending to treat, and civilians pretending to have suffered, symptoms of exposure to chemicals; transporting people killed elsewhere by armed opposition groups to either or both locations, to fake their death as a result of exposure to chemicals; manually placing a conventional cylinder, at both locations, where there was a pre-existing hole resulting from earlier conventional shelling, or one newly dug for “staging” purposes, or resulting from an explosive event; deliberately contaminating each location with household bleach or pesticides to resemble an area affected by a chlorine gas attack; dropping the cylinders from adjacent buildings or launching them from the ground in order to mimic airdropping from an aircraft.

4.4 In light of the above, the scenarios developed for this investigation can be succinctly summarised as follows:

- (a) chemical weapons were prepared elsewhere, brought to—or around—the site of the incidents identified by the FFM, and used; or
- (b) chemical weapons were air-delivered on—or around—the sites of the incidents identified by the FFM; or

---

<sup>24</sup> Note Verbale No. 3 from the Permanent Representation of the Russian Federation to the OPCW (dated 15 February 2022).

<sup>25</sup> See Annex 3 below.

<sup>26</sup> See “Approach and challenges in the investigation” above.

- (c) chemical weapons were launched, spread, or deployed otherwise to—or around—the sites of the incidents identified by the FFM; or
  - (d) no chemical weapons attack occurred, but conventional weapon(s) were deployed or brought to—or around—the sites of the incidents identified by the FFM, while chemicals were used at the sites later to “stage” a chemical attack and blame one side of the conflict.
- 4.5 For each of these scenarios, the IIT took into account that the operation to use chemicals (including by “staging” an incident) could have been organised through the chain of command of a formal or de facto structure, or that “rogue” units or individuals could have taken it upon themselves to use them.
- 4.6 In pursuing its investigation based on these scenarios, the IIT also took specific note of the categorical denials by the Syrian authorities of allegations that their Government used chemical weapons against the Syrian people and of the condemnations issued by the Syrian Arab Republic of the use of chemical weapons by anyone, anywhere, at any time, and under any circumstances.<sup>27</sup> The IIT also took into consideration the position expressed by both the Syrian Arab Republic and by the Russian Federation that the use of chemical weapons would have been futile from a military and political point of view.<sup>28</sup>

### **III. THE INCIDENT OF 7 APRIL 2018 IN DOUMA**

#### **5. BACKGROUND**

##### **The findings of the Fact-Finding Mission**

- 5.1 As noted above, the IIT is mandated to investigate those instances in which the FFM has determined that use or likely use of chemical weapons occurred, and for which the JIM did not reach findings as to the perpetrators. The FFM determined in its report that there were “reasonable grounds that the use of a toxic chemical as a weapon took place” on 7 April 2018 in Douma.<sup>29</sup> The FFM concluded that the toxic chemical “contained reactive chlorine”<sup>30</sup> and “was likely molecular chlorine”.<sup>31</sup> The FFM further assessed that it was “possible”<sup>32</sup> that “two yellow industrial cylinders”<sup>33</sup> found at the two sites

---

<sup>27</sup> See e.g. identical letters dated 11 March 2019 from the Permanent Representative of the Syrian Arab Republic to the United Nations addressed to the Secretary-General and the President of the Security Council, S/2019/250, 22 March 2019; Statement by H.E. Ambassador Bassam Sabbagh, Permanent Representative of the Syrian Arab Republic to the OPCW at the Twenty-Fourth Session of the Conference (C-24/NAT.40, dated 26 November 2019).

<sup>28</sup> United Nations Security Council, The Situation in the Middle East, 8195th meeting, 28 February 2018, S/PV.8195, 28 February 2018, pp.16-19.

<sup>29</sup> FFM Report on Douma, para. 9.12.

<sup>30</sup> FFM Report on Douma, para. 9.12.

<sup>31</sup> FFM Report on Douma, para. 9.12.

<sup>32</sup> FFM Report on Douma, para. 9.11.

<sup>33</sup> FFM Report on Douma, para. 9.7.

of alleged use of toxic chemicals “were the source of the substances containing reactive chlorine”.<sup>34</sup>

- 5.2 Chlorine, as a toxic chemical, can fall under the definition of a chemical weapon, under the general purpose criterion enshrined in Article 2 of the Convention.<sup>35</sup>

### **General situation in the area**

- 5.3 Before the conflict, eastern Ghouta was a densely populated and predominantly Sunni Muslim agricultural area, whose working-class suburbs and farming communities stretched across the outskirts of the capital, Damascus. Geographically, eastern Ghouta’s strategic importance rests within its position at the junction of two major roads: the M5 highway—a 450 km road connecting the capital to Jordan and to the country’s former economic hub of Aleppo; and the highway connecting Damascus to the city’s international airport.<sup>36</sup> In particular, eastern Ghouta’s largest subdistrict, Douma, is situated approximately 10 kilometres north-east of Damascus.
- 5.4 Eastern Ghouta was surrounded by key military infrastructure vital to the Syrian Arab Republic’s daily operations. The Syrian Armed Forces operated several army and air bases, as well as anti-aircraft positions to the North, South, East, and West of Douma, relying on the strategic roadways in the area. In particular, Douma and neighbouring Harasta were home to special forces, army, and other military logistics units, with the Syrian Special Forces Command being located only 7 km from Douma. However, the city’s strategic value was not limited to its geographical or military significance, but was also linked to its political and ideological influence.<sup>37</sup>
- 5.5 In 2011, eastern Ghouta became one of the first areas to join the uprising against the Syrian Arab Republic’s central government. Douma soon emerged as a hub for anti-Government demonstrations, often being referred to as the “political capital” of the armed opposition in eastern Ghouta.
- 5.6 Protests first took place in Douma on 25 March 2011, a week after unrest broke out in Daraa. On 1 April 2011, large demonstrations were reported in Douma, in which at least eight civilians were killed by the security forces. Military experts familiar with the conflict assess that the rapid escalation in the response by the security apparatus against local protests was largely because of the close proximity of Douma to Damascus, which may have been perceived as an imminent threat to the capital as protests grew. Violent crackdowns, mass detentions, and killings—intended to curb the reach of the

---

<sup>34</sup> FFM Report on Douma, para. 9.11.

<sup>35</sup> See above, Section I.2.1. See also, e.g., preambular paragraph 7 of Council Decision EC-M-50/DEC.1 (dated 23 November 2015).

<sup>36</sup> The IIT has previously indicated in its First and Second Report in – paragraph 6.6 and paragraph 5.2 respectively - the strategic importance of the M5 highway, noting that the value of the highway increased when authorities of the Syrian Arab Republic recapture eastern Aleppo city in late 2016; see First IIT Report, paras 6.6 and 6.7 and Second IIT Report, paras 5.2 and 5.3.

<sup>37</sup> Three years later, the symbolic significance of Douma was reaffirmed by Syrian President Bashar Al-Assad in statements given to Syrian media outlets after casting his ballot in the former rebel stronghold during the general elections of 26 May 2021; see <https://sana-syria/en/?tag=presidential-candidate-dr-bashar-al-assad-and-his-wife-voted-in-the-presidential-elections-in-douma-city-in-damascus-countryside>.

demonstrations reaching Damascus—continued to be reported, which further angered the local communities.<sup>38</sup> As a result, armed opposition groups began to emerge in eastern Ghouta, seizing territory and military bases from the Government and its army.

- 5.7 Military specialists consulted by the IIT assessed that Ghouta, outside the authority of the central government, posed a pressing existential risk to the authority of the Syrian Arab Republic's Government, with well-funded, organised, and militarily capable armed opposition groups being stationed within striking distance of the capital. In fact, indiscriminate shelling by armed opposition groups into Government-held civilian areas in the increasingly fortified Damascus grew in frequency and was duly documented by international human rights bodies.<sup>39</sup> In retaliation, government authorities cut off electricity and water supplies to eastern Ghouta and, by April 2013, had encircled the area, laying ground for the siege to come.
- 5.8 Between April 2013 and April 2018, forces of the Syrian Arab Republic and their allies laid the longest running siege in modern history.<sup>40</sup> Reports by United Nations human rights bodies have documented over the years how, throughout the siege, eastern Ghouta witnessed some of the worst atrocities of the entire conflict in the Syrian Arab Republic, leading Secretary-General Antonio Guterres to describe the situation in the enclave as “hell on earth”.<sup>41</sup> In turn, besieged populations and armed opposition groups began to depend on a network of smugglers and underground tunnels normally used for the provision of basic goods such as food, water, and medical supplies for the resupply of arms.<sup>42</sup>
- 5.9 By 2017, besieged eastern Ghouta was divided under the control of three competing rival factions as the Syrian Arab Army began to recapture surrounding territory. Ahrar Al-Sham (Freemen of the Levant), led by [REDACTED], came to control the town of Harasta. The south-west of the enclave was under the control of Faylaq Al-Rahman (Legion of Rahman), led by [REDACTED], and partially of Hayat Tahrir Al-Sham (Organization for the Liberation of the Levant), led by [REDACTED].<sup>43</sup> Douma and the north-eastern section of the enclave were under the control of Jaysh Al-Islam (Army of Islam), led by [REDACTED]. Throughout the siege, armed groups were accused of

---

<sup>38</sup> Human Rights Council, Report of the Independent International Commission of Inquiry on the Syrian Arab Republic, 16 August 2013, UN Doc. A/HRC/24/46, paras 40 – 110; Human Rights Council, The siege and recapture of eastern Ghouta, Conference room paper of the Independent International Commission of Inquiry on the Syrian Arab Republic, 20 June 2018, UN Doc. A/HRC/38/CRP.3, paras 37 – 38, 57, and 73.

<sup>39</sup> Human Rights Council, The siege and recapture of eastern Ghouta, Conference room paper of the Independent International Commission of Inquiry on the Syrian Arab Republic, 20 June 2018, UN Doc. A/HRC/38/CRP.3, paras 37-38, 57 and 73.

<sup>40</sup> Human Rights Council, The siege and recapture of eastern Ghouta, Conference room paper of the Independent International Commission of Inquiry on the Syrian Arab Republic, 20 June 2018, UN Doc. A/HRC/38/CRP.3, para. 20.

<sup>41</sup> See Secretary-General's remarks to the Human Rights Council [as delivered], 26 February 2018, available at <https://www.un.org/sg/en/content/sg/statement/2018-02-26/secretary-general-remarks-human-rights-council-delivered>.

<sup>42</sup> See High Commissioner for Human Rights Zeid Ra'ad Al Hussein, 27 October 2017 Syria: Suffering of civilians in Eastern Ghouta “an outrage” available at <https://www.ohchr.org/en/press-releases/2017/10/syria-suffering-civilians-eastern-ghouta-outrage-zeid>

<sup>43</sup> Eastern Ghouta Agreement between Jaysh Al-Islam and Faylaq Al-Rahman Brigade, Peace Agreements database, University of Edinburgh available at: <https://www.peaceagreements.org/view/1987>.

regularly committing crimes, which included indiscriminate attacks and shelling against areas under government control as well as the arbitrary arrest and torture of civilians in Douma.<sup>44</sup>

- 5.10 Jaysh al-Islam became the most prominent fighting force in Ghouta and was considered a hard-line Salafi militant group, controlling Douma from 2016 until its surrender in April 2018. The group was initially led by Mohammed Zahran Alloush, also known as Abu Abdullah. Over time and until his death in December 2015, he would establish himself as the central figure in the enclave's factional military landscape. He was replaced at the helm of the group by [REDACTED], also known as [REDACTED].
- 5.11 While it was under siege, a series of chemical attacks took place in eastern Ghouta, which were investigated by various international mechanisms. On 21 August 2013, a chemical attack was reportedly launched on Ghouta, reportedly killing hundreds of people. A United Nations team sent to investigate the incident and other allegations of use of chemical weapons in the Syrian Arab Republic found that "on 21 August 2013, chemical weapons [had] been used [...] on a relatively large scale",<sup>45</sup> and reported to have collected "clear and convincing evidence that surface-to-surface rockets containing the nerve agent Sarin were used in Ein Tarma, Moadamiyah and Zamalka in the Ghouta area of Damascus."<sup>46</sup> To date, the incident remains the deadliest instance of use of chemical weapons in the conflict in the Syrian Arab Republic, and several residents of eastern Ghouta reported to the IIT how the trauma and terror of that day remained still vivid in the collective memory of the civilian population.
- 5.12 A major assault by opposition forces in November and December 2017, leading to the almost complete encirclement of key military infrastructure of the Syrian Arab Army in Harasta, marked a shift in military operations against eastern Ghouta. Major shelling and ground operations began on 31 December 2017, signalling more robust and decisive efforts from the Government's side to retake the enclave once for all. In the months that followed, and prior to the 7 April 2018 incident in Douma, international human rights investigation mechanisms reported the use of chemical weapons in Douma on 22 January and 1 February 2018, and in Al-Shayfounia on 25 February 2018.<sup>47</sup>

---

<sup>44</sup> Human Rights Council, The siege and recapture of eastern Ghouta, Conference room paper of the Independent International Commission of Inquiry on the Syrian Arab Republic, 20 June 2018, UN Doc. A/HRC/38/CRP.3, paras 38 and 73.

<sup>45</sup> Report of the United Nations Mission to Investigate Allegations of the Use of Chemical Weapons in the Syrian Arab Republic on the Alleged Use of Chemical Weapons in the Ghouta area of Damascus on 21 August 2013, A/A/67/997-S/2013/553, 16 September 2013, paras 1, 27.

<sup>46</sup> Report of the United Nations Mission to Investigate Allegations of the Use of Chemical Weapons in the Syrian Arab Republic on the Alleged Use of Chemical Weapons in the Ghouta area of Damascus on 21 August 2013, A/A/67/997-S/2013/553, 16 September 2013, para. 28.

<sup>47</sup> Human Rights Council, The siege and recapture of eastern Ghouta, Conference room paper of the Independent International Commission of Inquiry on the Syrian Arab Republic, 20 June 2018, UN Doc. A/HRC/38/CRP.3, paragraph C.1. Analysts consulted by the IIT noted a possible correlation between the spike of reported chemical attacks in the Syrian Arab Republic, and in eastern Ghouta in particular, in the early months of 2018 with the discontinuation of the OPCW-United Nations Joint Investigation Mechanism (mandated, as per United Nations Security Council Resolutions 2235 (2015) and 2319 (2016) to identify perpetrators, organizers, sponsors or those otherwise involved in the use of chemicals as weapons in the Syrian Arab Republic) in October 2017.

## 6. INCIDENT IN DOUMA, 7 APRIL 2018

- 6.1 The FFM determined in its report that there were “reasonable grounds that the use of a toxic chemical as a weapon took place” on 7 April 2018 in Douma.<sup>48</sup> The FFM concluded that the toxic chemical “contained reactive chlorine”<sup>49</sup> and “was likely molecular chlorine”.<sup>50</sup> The FFM further assessed that it was “possible”<sup>51</sup> that “two yellow industrial cylinders”<sup>52</sup> found at the two sites of alleged use of toxic chemicals “were the source of the substances containing reactive chlorine”. The IIT understands its mandate to be based on the findings of the FFM; it therefore focused its investigation on the possible perpetrators of the use of chlorine and also took into account information about the presence of other substances.
- 6.2 In fulfilment of its task to identify perpetrators, and taking into account the constraints under which the IIT is working,<sup>53</sup> the IIT examines various scenarios,<sup>54</sup> including various avenues of inquiry regarding the allegation that barrels containing chlorine were placed at the scene to “stage” a chemical attack.
- 6.3 The IIT therefore focused in this case on the two main scenarios, i.e., that of the “staging” of a chemical attack, and that of an attack with chlorine released through cylinders dropped from the air. At the same time, the IIT remained open to other hypotheses that could explain what happened on 7 April 2018 in Douma.

### The context of military activities in the area

- 6.4 With regard to the military activities in the area of Douma, eastern Ghouta, in early 2018, the IIT made its assessments on the basis of accounts by witnesses, expert reports, technical and observation data, as well as imagery and open-source information, and through consultation with external entities and experts.
- 6.5 Following the recapture of Deir ez-Zor from the Islamic State of Iraq and the Levant (ISIL) in November 2017 and the North Western Campaign from October 2017 to February 2018, the Syrian Arab Army shifted its focus on retaking all opposition-held territory across eastern Ghouta in an offensive referred to as “Operation Damascus Steel”.
- 6.6 While the IIT has not received conclusive information as to the formal appointment of a commander for Operation Damascus Steel, credible sources indicate that Brigadier-General Souheil al-Hassan, commander of the Tiger Forces (*Quwwat al-Nimr*), an elite unit employed on various fronts of the conflict in the Syrian Arab Republic, played a leading role in the operation, having been delegated a considerable degree of (if not overall) command responsibility alongside Republican Guard units commanded by [REDACTED]. [REDACTED] involvement in the operation was confirmed to the IIT by a number of reliable sources. It was further corroborated through images and videos showing [REDACTED] presenting updates and future plans related to the

---

48 FFM Report on Douma, para. 9.12.

49 FFM Report on Douma, para.9.12.

50 FFM Report on Douma, para. 9.12.

51 FFM Report on Douma, para. 9.11.

52 FFM Report on Douma, para. 9.7.

53 See Section 3 above; *cf.* First IIT Report, Section II.4.

54 See Section 4 above; *cf.* First IIT Report, Section II.5.



offensive in a meeting with President Bashar Al-Assad, during his visit to eastern Ghouta on 18 March 2018. Moreover, credible information provided to the IIT suggests that [REDACTED] was present in Douma in April 2018.<sup>55</sup>

- 6.7 According to information obtained by the IIT, on 13 February 2018 the Tiger Forces began to arrive in eastern Ghouta, their deployment to the area having been corroborated through images and videos posted on accounts linked to both the Syrian Arab Army and the Tiger Forces. On 17 February 2018, Brigadier-General al-Hassan was filmed delivering a speech to his troops, while surrounded by security detail provided by the Russian Federation. In his speech—referring to enemy forces in eastern Ghouta—he promised to “teach them a lesson, in combat and in fire”.
- 6.8 A day later, on 18 February 2018, the Syrian Arab Republic Forces, alongside the Tiger Forces and other Syrian and foreign militias—and supported by Russian Federation forces—launched a full-scale air and ground assault to recapture eastern Ghouta.
- 6.9 The IIT received credible information suggesting that Brigadier-General al-Hassan set up operations in Dumayr airbase, located approximately 32 km south-east of Douma (33° 36' 49.9" N 36° 44' 42.5"E). Further, credible information indicates that the Tiger Forces were assigned a helicopter squadron at Dumayr airbase consisting of at least seven Mi-8/17 helicopters, in order to support their operations throughout the eastern Ghouta offensive. Information received by the IIT from several independent sources indicates these helicopters, while belonging to the 63rd Brigade, operated under the direct command and control of Brigadier-General al-Hassan.
- 6.10 Satellite imagery and other sources assessed by the IIT corroborate the movement of forces and military assets to Dumayr airbase from February 2018 onwards. Satellite imagery shows a significant increase in the level of vehicle activity as of 19 February 2018, with new temporary structures (with an unknown purpose), tents, and other equipment being newly visible on the Dumayr airbase aprons. Satellite imagery captured on 20 February 2018 further indicates the presence of helicopters on aprons at Dumayr airbase, which had previously been unoccupied. This coincides with the deployment of the Tiger Forces to eastern Ghouta and with the start of the offensive.
- 6.11 The day of 19 February 2018 marked a week-long intensified air campaign, led by the Syrian Arab Air Force and the Russian Aerospace Defence Force, targeting vital civilian infrastructure, including multiple airstrikes on hospitals and other specially protected objects.<sup>56</sup> Flight observation data obtained by the IIT, supported by witness statements, indicates that on 19 February, 28 Mi-8/17 helicopters were observed departing from Dumayr airbase, with a total of 224 Mi-8/17 take-offs by 26 February 2018. On 24 February, the United Nations Security Council passed resolution 2401, calling for an immediate cease-fire and a 30-day humanitarian pause. However, ground

---

<sup>55</sup> See videos of President Bashar Al-Assad visiting bases of Republican Guards during the eastern Ghouta offensive on 18 March 2018. Available at <https://www.youtube.com/watch?v=AuLL8FxM6U> and <https://www.youtube.com/watch?v=AjXgGLDOBbU>

<sup>56</sup> See Independent International Commission of Inquiry on the Syrian Arab Republic, “The siege and recapture of eastern Ghouta”, A\_HRC\_38\_CRP\_3\_EN, 20 June 2018, paras. 45-47, available at: [https://www.ohchr.org/A\\_HRC\\_38\\_CRP\\_3\\_EN\\_Section\\_IX\\_A59](https://www.ohchr.org/A_HRC_38_CRP_3_EN_Section_IX_A59).

shelling and airstrikes continued, with critical support provided to ground operations by Russian military aircraft departing from Hmemeim airbase.

- 6.12 The IIT has received credible information, corroborated through multiple sources, according to which Russian forces were co-located at Dumayr airbase alongside the Tiger Forces. This is consistent with the IIT's understanding, based on the extensive review of military analysis and of Russian and Syrian public statements and open sources that, already prior to the eastern Ghouta offensive, and since the early stages of the intervention of the Russian Federation in the conflict in the Syrian Arab Republic, the relationship between the Tiger Forces and the Russian Forces was one of special proximity and close coordination at the operational and tactical level. In November 2017, General Valery Gerasimov, Chief of Staff of the Russian Federation's armed forces, praised Brigadier-General [REDACTED] and his units for their role in the most important battles across the Syrian Arab Republic alongside Russian officers. Soon after, in December 2017, Brigadier-General [REDACTED] was the only Syrian military commander to attend a meeting alongside Syrian President Bashar Al-Assad with Russian President Vladimir Putin. The Russian President personally congratulated Al-Hassan on his military achievements during the Deir-er-Zor offensive against ISIL.
- 6.13 In relation to the above, analysts consulted by the IIT noted that the Russian Federation and its armed forces played a broader role in the eastern Ghouta offensive that was not limited to airstrike and combat support. Internationally, the Russian Federation offered political support to the Syrian Arab Republic actively participating in discussions on the Syrian Arab Republic across the United Nations Security Council, as well as calling for press briefings and Arria formula meetings in relation to the Ghouta offensive. Locally, Russian diplomats coordinated with aid groups following the recapture of Ghouta, and Russian armed forces, under the command of Colonel-General Alexander Alexandrovich Zhuravlyov, stationed across the Syrian Arab Republic negotiated surrenders and deals with armed groups on behalf of the Syrian Government. Upon the surrender of besieged towns the Russian Federation offered military police to ensure that convoys departed in a timely manner and upheld agreements in the recaptured cities.
- 6.14 The IIT has also obtained information attesting to the continued linkages between the Tiger Forces and the Syrian Air Force Intelligence throughout Operation Damascus Steel. At the time of the chemical attack on Douma, the Syrian Air Force Intelligence fell under the National Security Bureau headed by Major-General [REDACTED].
- 6.15 Throughout the offensive on Ghouta, leaflets were dropped over Douma, Harasta, and Irbin to persuade the besieged populations to join local reconciliation initiatives and to hand themselves over to the Syrian Arab Army in order to "save their lives". On 22 February, helicopters of the Syrian Arab Air Force dropped leaflets<sup>57</sup> over Ghouta urging local residents to flee the enclave and for armed opposition fighters to lay down their weapons and surrender, promising them amnesty in return.

---

57

See Independent International Commission of Inquiry on the Syrian Arab Republic, "The siege and recapture of eastern Ghouta", A\_HRC\_38\_CRP\_3\_EN, 20 June 2018, paragraph 59, available at: [https://www.ohchr.org/A\\_HRC\\_38\\_CRP\\_3\\_EN](https://www.ohchr.org/A_HRC_38_CRP_3_EN), Section IX A59.

- 6.16 As noted above,<sup>58</sup> on 25 February an attack took place in al-Shayfouniya in eastern Ghouta, where chlorine was reported to have been used. Less than a month later, on 20 March, following sustained fighting, Harasta became the first of the three eastern Ghouta enclaves to be recaptured by Syrian Government forces. Shortly after, on 23 March, Arbin, Jobar, Zamalka, and Ain Tarma were also recaptured following negotiations brokered by the Russian Federation. As a result, civilians and fighters of Ahrar al-Sham and Faylaq al-Raqman were evacuated to opposition-held areas in the north-west of the Syrian Arab Republic. Therefore, Douma remained the last opposition-held bastion in eastern Ghouta, with Jaysh al-Islam refusing to surrender.
- 6.17 Aircraft activity originating from Dumayr airbase continued until 23 March, followed by a 10-day lull. The temporary suspension of air operations coincided with negotiations taking place between Jaysh al-Islam and representatives of the Syrian Arab Republic, mediated by the Russian Ministry of Defense's representative, General Alexander Zorin.<sup>59</sup>
- 6.18 The negotiations continued through early April, yielding no results. Simultaneously, on 28 March, pro-Government media reported that that Syrian forces were mobilising around Douma and preparing a major assault, should the negotiations with Jaysh al-Islam fail. As of that date, according to United Nations sources,<sup>60</sup> 70,000 people remained besieged in the enclave.
- 6.19 On 6 April, negotiations between Jaysh al-Islam and the Russian Federation broke down. Amid reports of shelling on Damascus suburbs from Jaysh al-Islam positions, intense airstrikes resumed on Douma after a 10-day break. This is confirmed by flight observation data showing 28 Mi-8/17 helicopter take-offs on the same day. A video posted by two YouTube channels shows a videotaped radio communication dated 6 April 2018, in which Brigadier-General [REDACTED] orders his troops to start the military operations on Douma. The same video was posted by the Facebook page of the "Tiger Forces in the Field/Al-Hawarth Regiment".
- 6.20 On the evening of 7 April, as the barrage of large-scale conventional shelling continued, reports of a chemical attack on two locations in Douma started circulating on social media. Dozens of casualties were reported by medical staff on the ground. The IIT did not obtain any information indicating that military targets had been placed in proximity to either location.
- 6.21 A few hours after the attack, on the morning of 8 April 2018, Jaysh al-Islam negotiated its surrender with the Russian mediators. The agreement involved the evacuation of fighters to Northern Syria, the possibility to reconcile for those who decided to stay and surrender their weapons, as well as the release of prisoners held by Jaysh al-Islam.

---

<sup>58</sup> See above "General situation in the area".

<sup>59</sup> Described by United Nations sources as "one of the key military commanders and in charge of much of the negotiations locally in Syria", see Note to correspondents: Transcript of Press Stakeout by Senior Adviser to the United Nations Special Envoy for Syria, Jan Egeland, 9 August 2018, available at: [www.un.org/sg/en/content/sg/note-correspondents/2018-08-09/note-correspondents-transcript-press-stakeout-senior](http://www.un.org/sg/en/content/sg/note-correspondents/2018-08-09/note-correspondents-transcript-press-stakeout-senior).

<sup>60</sup> See OCHA Situation Report, 26 March 2018, <https://reliefweb.int/report/syrian-arab-republic-east-ghouta-displacement-situation-report-no-1-26>.

- 6.22 According to insiders privy to the content of the negotiations and interviewed by the IIT, the pressure on the civilian population following the chemical attack, as well as the warning by pro-Government forces that the shelling would continue and intensify had the group not accepted to negotiate, played a key role in the decision by Jaysh al-Islam's leadership to eventually surrender.
- 6.23 Russian media broadcast Russian General Alexander Zorin and other Russian military officers visiting, on 9 April 2018, one of the two buildings targeted by the 7 April chemical attack (i.e. Location 2).<sup>61</sup> In addition, according to a briefing posted on the website of the Russian Ministry of Defense on 9 April, the Russian Centre for Reconciliation of Opposing Sides in Syria stated that representatives did not find any evidence of affected individuals or chemical weapons use in Douma.<sup>62</sup>
- 6.24 On 12 April, the Russian Ministry of Defense announced that the Syrian Government's flag was flying in Douma, and that the Russian Military Police had begun to patrol the city.<sup>63</sup> Two days later, a spokesperson for the General Command of the Army and Armed Forces announced that all Jaysh al-Islam fighters had "left Douma, the last of their holdouts in Eastern Ghouta."<sup>64</sup>
- 6.25 In the early hours of 14 April, Syrian local time, France, the United States of America, and the United Kingdom of Great Britain and Northern Ireland launched airstrikes in the Syrian Arab Republic in response to the chemical attack in Douma. The airstrikes targeted the Barzah Research and Development Centre near Damascus, as well as the Him Shinshar military installation near Homs.<sup>65</sup>
- 6.26 The Tiger Forces were reported to have departed to East Qalamoun from Douma as early as 18 April, as operations began there to recapture the eastern Qalamoun mountains.

### **Meteorological conditions**

- 6.27 Sunset on 7 April 2018 was at around 18:59; sunrise on the next day was at around 06:14. The IIT established the meteorological conditions in the area of Douma, in the Syrian Arab Republic on the evening of 7 April 2018 based on official reports by the World Meteorological Organization (WMO), its specialised meteorological centres, witness accounts, publicly available historical weather data, and other sources of information. The IIT acknowledges that meteorological conditions may vary slightly depending on the weather station closest to Douma, therefore the conditions noted below are indicative of the forecast in the general area within a 20 km radius of the

---

<sup>61</sup> See Facebook archive of broadcast on BECTN news, 10 April 2018, available at <https://facebook.com/vesti.ru/videos/2000316960002798/>

<sup>62</sup> See [Briefing by Centre for Reconciliation of Opposing Sides in Syria \(April 9, 2018\) : Ministry of Defence of the Russian Federation \(archive.org\)](#).

<sup>63</sup> See also posted on the official Facebook Page of Russian Ministry of Defence: <https://web.archive.org/web/2020625025851/https://facebook.com/mod.mil.rus/photos/a.1492313031011448.1073741828.1492252324350852/2076257962616949/?type=3&theater;>

<sup>64</sup> See Syrian Arab News Agency report, Army General Command announces Eastern Ghouta clear of terrorism, 14 April 2018 available at: <https://sana.sy/en/?p=134412>

<sup>65</sup> United Nations Security Council, 8233<sup>rd</sup> Meeting, 14 April 2018; S/PV.8233; Independent International Commission of Inquiry on the Syrian Arab Republic, "The siege and recapture of eastern Ghouta", A\_HRC\_38\_CRP\_3\_EN, 20 June 2018, para. 10.

incident site, rather than the exact weather conditions in the exact location at the time in which the incident occurred.

- 6.28 According to the WMO data analysed by the IIT, between 19:00 and 20:00 the area experienced a temperature of 23.9° C (with a possible margin of error of about 2° C) and 18% relative humidity at 2 m above ground. Wind speed (measured to reflect an average within a 60-minute margin) at the time of the attack was estimated as travelling at 3 m/s (i.e. 11 km/h) from a south-westerly direction. Models of the area show the wind direction and speed over the course of the evening remained between 2 m/s and 3 m/s from a south-westerly direction until 21:00 that evening, where models indicate a slight wind change to winds coming from a west to north-westerly direction. The conditions noted in the area at the time of the incident are considered permissive<sup>66</sup> for the use of chlorine gas, since the latter would have remained close to the point of release owing to the light winds. Thus, a decision maker with knowledge of such conditions and seeking to maximise the effectiveness of such gas would have been able to plan and use it as a chemical weapon in these circumstances—although the exact direction of any gas dispersion could not have been accurately foreseen in advance.

Time	Temperature	Wind Direction	Wind Speed m/s	Precipitation	Clouds TCC <sup>67</sup>	Humidity
19:00	23.9 Celsius	SW	3 m/s	0.0 mm	14%	18%
20:00	22.6 Celsius	WNW	2 m/s	0.0 mm	28%	19%

### Chemical analyses

- 6.29 The FFM determined in its report that there were “reasonable grounds that the use of a toxic chemical as a weapon took place” on 7 April 2018 in Douma.<sup>68</sup> The FFM further concluded that the toxic chemical “contained reactive chlorine”<sup>69</sup> and “was likely molecular chlorine.”<sup>70</sup>
- 6.30 The term “reactive chlorine”, as used in the FFM Report, includes molecular chlorine (i.e. chlorine gas (Cl<sub>2</sub>)), hypochlorous acid, and sodium hypochlorite (i.e. the active substance in bleach).<sup>71</sup> Chlorine has many industrial uses—water purification, disinfectants, bleach, and the manufacture of many products, including papers, antiseptics, dyes, foods, paints, petroleum products, plastics, medicines, textiles, and

<sup>66</sup> In regard to the permissiveness of use of chemical weapons under different meteorological conditions, the IIT consulted with specialists, but also took into account examples and studies of chemical weapons use during the 20th century—with the required caution as to the type of agents involved. See e.g.: A. M. Prentiss, *Chemicals in War – a Treatise on Chemical Warfare* (New York and London, 1937), especially pp. 23-34; M. Sartori, *The War Gases – Chemistry and Analysis* (New York, 1939), especially pp. 2-15; A. T. Tu, *Chemical Terrorism* (Fort Collins, 2002).

<sup>67</sup> TCC = total cloud cover.

<sup>68</sup> See FFM Report on Douma, para. 9.12.

<sup>69</sup> See FFM Report on Douma, para. 9.12.

<sup>70</sup> See FFM Report on Douma, para. 9.12.

<sup>71</sup> See FFM Report on Douma, para. 8.15.

solvents. The annual global production of chlorine gas is about 65 million tonnes, and it is traded as compressed, liquefied gas, stored in pressurised cylinders.

- 6.31 For the purpose of this report, the terms “molecular chlorine” and chlorine gas (the colloquial term for “molecular chlorine”) will be used interchangeably. Chlorine gas is a highly reactive and toxic gas, with a density 2.5 times higher than air. Thus, once released, chlorine gas will sink to low-lying areas at the site of release.
- 6.32 Chlorine gas is not persistent in the environment because of its high chemical reactivity. Chemical reactions with a wide range of compounds in the environment will deplete any released chlorine gas within hours.<sup>72</sup>
- 6.33 The FFM further assessed that it was “possible”<sup>73</sup> that “two yellow industrial cylinders”<sup>74</sup> found at the two sites of alleged use of toxic chemicals “were the source of the substances containing reactive chlorine.”<sup>75</sup>
- 6.34 Chlorine gas reacts rapidly with water (or moisture in air) to produce hypochlorous acid and hydrochloric acid. The reaction of chlorine with aqueous sodium hydroxide will produce sodium hypochlorite, the reactive ingredient in household bleach products. Both chlorine gas and bleach have the capacity to react with organic molecules in the environment to produce their chlorinated analogues. However, chlorine gas has a higher chemical reactivity than sodium hypochlorite, the active ingredient in bleach products. Chlorine gas at high concentrations has therefore the potential to produce more highly chlorinated analogues (i.e. chlorinated phenols) than bleach.
- 6.35 Chlorine gas is more fat-soluble than the highly water-soluble hypochlorite ion present in bleach solutions. This feature of chlorine gas allows it (in contrast to hypochlorite) to diffuse into materials with a fatty character (i.e. plastic, dried paint and synthetic fabric), thereby accessing suitable organic molecules present within fatty material and allowing the formation of their chlorinated analogues.
- 6.36 The IIT undertook a number of steps to clarify and deepen its understanding of the findings by the FFM that reactive chlorine was used as a weapon in Douma on 7 April 2018 at two sites, and that the toxic chemical “was likely molecular chlorine”.<sup>76</sup> In taking such steps, the IIT also considered the FFM’s assessment that it was “possible”<sup>77</sup> that “two yellow industrial cylinders”<sup>78</sup> found at the two sites of alleged use of toxic chemicals “were the source of the substances containing reactive chlorine.”<sup>79</sup>

---

<sup>72</sup> The rate of chlorine degradation is dependent on weather conditions such as temperature and humidity.

<sup>73</sup> See FFM Report on Douma, para. 9.11.

<sup>74</sup> See FFM Report on Douma, para. 9.7.

<sup>75</sup> See FFM Report on Douma, para. 9.11.

<sup>76</sup> See FFM Report on Douma, para. 9.12.

<sup>77</sup> See FFM Report on Douma, paras 2.16 and 9.11.

<sup>78</sup> See FFM Report on Douma, paras 2.12 and 9.7.

<sup>79</sup> See FFM Report on Douma, para. 9.11.

- 6.37 To do so, the IIT assessed relevant analytical chemistry data underlying the FFM Report, as provided by the two OPCW designated laboratories<sup>80</sup> used by the FFM to analyse relevant samples.
- 6.38 At the time of its investigation, the FFM visited Location 2 (coordinates: N 33° 34' 25.6'' E 36° 24' 17.3'') on 21 April 2018<sup>81</sup> (i.e. 14 days after the incident occurred) and Location 4 (coordinates: N 33° 34' 20.5'', E 36° 24' 02.8'') on 25 April 2018<sup>82</sup> (i.e. 18 days after the incident).<sup>83</sup> During its visit, the FFM collected 44 samples from Location 2<sup>84</sup> and 20 samples from Location 4, including dry and wet wipes of surfaces, concrete debris, wood, fabric, plastic material, paint flakes, and metal and biomedical samples of victims.<sup>85</sup> A subset of those samples was sent out for analysis to two OPCW designated laboratories with a view to identifying the presence of “scheduled chemicals and degradation products” and “chlorinated organic chemicals”.<sup>86</sup>

---

<sup>80</sup> These are all laboratories that have successfully performed in the proficiency testing of the OPCW and offer the necessary assurances to States Parties in terms of competence, impartiality, and unambiguous results in relation to the analysis of chemical samples, in accordance with the Conference decision entitled “Criteria for the Designation of Laboratories by the OPCW” (C-I/DEC.61, dated 22 May 1997).

<sup>81</sup> FFM Report on Douma, para. 8.21 and Annex 3, page 39.

<sup>82</sup> FFM Report on Douma, para. 8.32 and Annex 3, page 39.

<sup>83</sup> At the time of the FFM’s visit, the security of both locations was ensured by the Russian Military Police; see para. 2 of the “Update by the Director-General on the Deployment of the OPCW Fact-Finding Mission to Douma, Syrian Arab Republic, to the Council at Its Fifty-Ninth Meeting” (EC-M-59/DG.2, dated 18 April 2018): “The security for the sites where the FFM plans to deploy was under the control of the Russian Military Police”.

<sup>84</sup> Five additional samples relating to Location 2 were handed over to the FFM by a witness; see FFM Report on Douma, Table A9.3, item 94.

<sup>85</sup> See FFM Report on Douma, Annex 5.

<sup>86</sup> See FFM Report on Douma, para. 2.6; Annex 4, para. 7; and Annex 5.



**FIGURE 1: MAP OF RELEVANT LOCATIONS IN DOUMA**



- 6.39 The search for chlorinated organic chemicals was based on the knowledge that chlorine gas has the characteristic capacity to chlorinate specific chemicals in the environment. Therefore, when released, chlorine gas would rapidly undergo chemical reactions with environmental chemicals to produce chlorinated versions of those chemicals. Thus, although chlorine gas is rapidly depleted after being released, the chlorinated chemicals resulting from its reaction with the surrounding environment may have scientific relevance as chlorine markers.<sup>87</sup>
- 6.40 The analytical results of the two OPCW designated laboratories included the identification of chlorinated chemicals. These results led to the FFM’s conclusion that “based on the levels of chlorinated organic derivatives, detected in several environmental samples gathered at the sites of alleged use of toxic chemicals (Location 2 and 4), which are not naturally present in the environment [...] the objects from which the samples were taken at both locations had been in contact with one or more substances containing reactive chlorine.”<sup>88</sup>
- 6.41 In considering the FFM’s analytical findings, the IIT focused specifically on an anthropogenic subset of the identified chlorinated organic chemicals (i.e. chemicals which are not naturally present in the environment). The lack of natural sources of the considered chlorinated chemicals limits the potential explanations for their presence to

<sup>87</sup> Cf. FFM Report on Douma, para. 8.9.

<sup>88</sup> See FFM Report on Douma, paras 2.6 and 9.1.



- chemical events involving reactive chlorine (i.e. industrial chemical production or release in nature by man).
- 6.42 The FFM did not make any findings related to the use of organophosphorous nerve agents in Douma on 7 April 2018.<sup>89</sup> The IIT confirmed that no analytical results supported this hypothesis. Therefore, the IIT did not pursue this line of inquiry.
- 6.43 In addition to assessing the analytical data supporting the FFM Report, as relating to Location 2 and Location 4 (for a total of 68 samples), the IIT also undertook the analysis of two supplementary samples. These include the sample of an electrical copper wire from Location 2 (27SDS) which had not previously been analysed by the FFM. The IIT ascertained that the sample had been maintained in pristine conditions at the OPCW Laboratory since it was transferred to it in May 2018,<sup>90</sup> in accordance with OPCW procedures.<sup>91</sup> The sample was analysed by a specialised forensic institution.
- 6.44 A second supplementary sample (concrete) collected by a third party at Location 2 in Douma on 8 April 2018—and whose chain of custody the IIT was able to reconstruct between the date it was collected and the date it was first received and analysed by an OPCW designated laboratory on 24 July 2018<sup>92</sup>—was analysed by a third OPCW designated laboratory. The IIT further considered relevant videos and pictures obtained by both the IIT and the FFM, as well as open-source materials as appropriate, in order to gain further understanding of the sites of sampling and of the layout of the relevant buildings at both locations.
- 6.45 The IIT engaged a well-established chemist with specific expertise in the analysis of chlorine markers (not previously involved in the analysis, assessment, and interpretation of samples from Douma) as an expert to assist the investigation in relation to the results of sample analyses and their significance. The expert researched relevant scientific literature and consulted other chemists and specialists, as appropriate.
- 6.46 Starting from an analysis of the FFM findings (i.e., as noted above, that “the toxic chemical contained reactive chlorine. The toxic chemical was likely molecular chlorine”),<sup>93</sup> the expert was asked, *inter alia*, whether they had reasonable grounds to believe that, at both the relevant sites (i.e. Locations 2 and 4): (1) molecular chlorine (i.e. chlorine gas) was used as suggested by the FFM in its conclusions on the incident<sup>94</sup> (as opposed to other sources of reactive chlorine); and (2) chlorine gas was released from the two cylinders, one per each relevant location (as assessed as “possible” by the FFM in its conclusions on the incident).<sup>95</sup> This included an assessment of the

---

<sup>89</sup> See FFM Report on Douma, paras 2.7 and 9.2.

<sup>90</sup> Upon the FFM’s return to OPCW Headquarters from the Syrian Arab Republic, see FFM Report on Douma, Annex 3, page 40.

<sup>91</sup> See Annex 2, para. 9.

<sup>92</sup> OPCW designated laboratories, which operate under a quality system in accordance with International Organization for Standardization/International Electrotechnical Commission standard ISO/IEC 17025, are also obliged to maintain the chain of custody of the samples throughout their processes; see Annex 2, para. 11.

<sup>93</sup> See FFM Report on Douma, paras 2.17 and 9.12.

<sup>94</sup> See FFM Report on Douma, paras 2.17 and 9.12.

<sup>95</sup> See FFM Report on Douma, paras 2.16 and 9.11.

presence/absence and, if present, of the significance of chlorinated organic molecules (chlorine markers) in samples analysed and their relevance to the current incident.

- 6.47 While doing so, the expert was asked to give particular consideration to the hypothesis that household bleach products could have been brought to both locations to “stage” a chlorine gas attack with otherwise conventional gas cylinders.

Location 2 (“cylinder on the roof”)

*Findings*

- 6.48 Chlorinated organic chemicals were identified in concrete samples collected at Location 2 and analysed by two different OPCW designated laboratories.
- 6.49 The FFM collected a sample of concrete debris at the crater’s edge (in front of the cylinder’s orifice) (19SLS) at Location 2, in which trichlorophenol (TCP) was identified. The IIT further considered an additional sample—collected in the room under the crater and the cylinder, on the third floor of the building. The sample was analysed by a third OPCW designated laboratory, which identified TCP and tetrachlorophenol (TeCP) in the sample.
- 6.50 The total set of data supports the identification of chlorinated phenols at Location 2 by three different OPCW designated laboratories, confirming the presence of a chlorinating agent at the scene.
- 6.51 The exposure of phenolic precursors to bleach or chlorine gas would, stepwise, produce monochlorophenol (MCP), dichlorophenol (DCP), and TCP. However, chlorine gas has a much higher reactivity for the chlorination of phenols than the hypochlorite ion present in bleach.<sup>96</sup> The three chlorine atoms of TCP dramatically decrease its chemical reactivity by a reduction of the electron density in the aromatic electron system. Therefore, to produce TeCP from TCP through the addition of a fourth chlorine atom, the high reactivity of chlorine gas is required.
- 6.52 Therefore, the presence of highly chlorinated phenol, TeCP, in the concrete sample collected at Location 2 specifically points to the exposure to chlorine gas of phenolic precursors (present in the concrete). The fact that the (difficult)<sup>97</sup> conversion from TCP to TeCP took place at the scene further attests to the presence of chlorine gas in very high concentrations.<sup>98</sup> Therefore, the presence of TeCP clearly points to chlorine gas as being the chlorinating agent present at the scene, and in very high concentrations.

---

<sup>96</sup> See e.g. S. S. Lau, S. M. Abraham and A. L. Roberts (2016), “Chlorination revisited: Does Cl<sup>-</sup> serve as a catalyst in the chlorination of phenols?”, in *Environ. Sci. Technol.* (2016), vol. 50 (Dec 2016), pp. 13291-13298.

<sup>97</sup> As mentioned above, chlorine gas has a much higher reactivity than sodium hypochlorite in bleach, but TCP can be formed by chlorination of phenols using both species of reactive chlorine. However, the three chlorine atoms of TCP dramatically decrease the latter’s chemical reactivity. Therefore, to produce TeCP from TCP through the addition of a fourth chlorine atom, the highly reactive chlorine gas is required (as opposed to bleach).

<sup>98</sup> See e.g. F. Muller and L. Caillard (2012), “Chlorophenols”, in *Ullmann’s Encyclopedia of Industrial Chemistry* (2012), DOI: 10.1002/14356007.a07\_001.pub2.

- 6.53 The presence of chlorine gas in high concentrations, right under the cylinder in the room on the third floor of the building, is also consistent with two dispersion models obtained by the IIT. In the two models, computational fluid dynamics were used to reconstruct the distribution of chlorine gas in the building at the time of the incident.<sup>99</sup>
- 6.54 The direct leakage through the aperture in the roof of the dense chlorine gas (which is 2.5 times heavier than air) into the room on the third floor would promote the formation of the highly chlorinated phenol TeCP, in line with the estimation of a peak chlorine gas concentration right under the cylinder.
- 6.55 Both gas dispersion models obtained by the IIT also show the cloud of chlorine gas flowing from the balcony (situated on the opposite side of the building compared to the street) down into the building's lower floors, and leaking out onto the street through the building's main door and windows. This is in line with the analytical results indicating a lower load of a gaseous chlorinating agent in the concrete samples collected on the street.
- 6.56 In a supporting study considered by the IIT, two concrete debris samples collected by the FFM—one across the street from the entrance to the building (02SLS) and one control sample collected 20 metres west of the entry to the building (04SLS)—were analysed. MCP and DCP were identified in sample 02SLS. The control sample 04SLS did not contain reportable levels of chlorinated phenols. The absence of highly chlorinated phenols in both samples suggests that the TCP and TeCP identified in the building were generated through the action of a chlorinating agent, such as chlorine gas, and not by the general contamination of the environment linked, for example, to the use of chlorinated phenols as pesticides.

**FIGURE 2: SAMPLES COLLECTED AT LOCATION 2 CONSIDERED BY THE IIT**



<sup>99</sup> See also “Symptoms of affected persons” section below.

- 6.57 The pattern of detected chlorinated phenols at the scene is consistent with the hypothesis that the cylinder on the roof was the source of the released gaseous chlorinating agent.<sup>100</sup> This is indicated by the presence of highly chlorinated phenols TCP and TeCP at the sampling locations close to the cylinder (i.e. at the crater on the roof and in the room under the cylinder), as opposed to the least chlorinated phenols MCP and DCP on the street far away from the cylinder.
- 6.58 While investigating the scenario of a possible “staging” of the incident, e.g. through the spreading of bleach, the IIT has duly considered that the production of TCP has also been reported in scientific literature as a result of the application of the reactive chlorine species sodium hypochlorite, i.e. the active ingredient in bleach.<sup>101</sup> However, the further chlorination to produce TeCP from the reaction of bleach with TCP has not been scientifically documented, which is consistent with the fact that sodium hypochlorite in bleach is a less reactive chlorinating agent than chlorine gas.<sup>102</sup>
- 6.59 Mindful that the highly chlorinated species TeCP has been spread in nature as a minor contamination (5-10%) in pentachlorophenol (PCP)-based pesticides, the IIT has also considered the hypothesis whereby the presence of TeCP in samples collected at Location 2 may have been due to the pre-existing use of PCP-based pesticides in Douma. However, this explanation is at odds with—and cannot explain—the presence of TeCP in the absence of PCP in the relevant concrete sample collected from the residential building at Location 2. In the environment, there is no chemical degradation mechanism of PCP to produce TeCP known in scientific literature. Furthermore, no metabolic route for chlorinated phenols by aerobic microorganisms would selectively degrade PCP while preserving TeCP. This further supports the hypothesis that TeCP was produced in situ from phenolic precursors reacting with chlorine gas at very high concentrations.<sup>103</sup>
- 6.60 The FFM also collected four wood samples from Location 2. In a sample taken from the wood support of a water tank in the building’s basement (32SDS), both the chlorinated chemicals bornyl chloride (BC)<sup>104</sup> and TCP<sup>105</sup> (as well as the conifer-specific

---

<sup>100</sup> This would also be consistent with the auto-refrigeration phenomenon documented in a video taken at Location 2 one hour after the attack, and whose metadata the IIT was able to verify. The frost observed on the cylinder supports the hypothesis that a compressed liquefied gas was released from the cylinder at the time of the incident. See “Assessment of remnants” section below.

<sup>101</sup> See e.g. C. Prasse, U. von Gunten and D.L. Sedlak, (2020), “Chlorination of Phenols Revisited: Unexpected Formation of *a,b*-Unsaturated C4-Dicarbonyl Ring Cleavage Products” in *Environ Sci Technol.*, (2020), Vol.54 (2), (January 2020), pp. 826-834.

<sup>102</sup> See e.g. J. D. Sievey and A. L Roberts, “Assessing the reactivity of free chlorine constituents Cl<sub>2</sub>, Cl<sub>2</sub>O and HOCl towards aromatic ethers.” In *Environ. Sci. Technol.* (2012), vol 46 (4), (February 2012) pp. 2141-2147; M. Nunez-Gaytan et al., “Speciation and transformation pathways of chlorophenols formed from chlorination of phenol at trace level concentration” in *Journal of Environmental Science and Health, Part A*, vol. 45 (June 2010) pp. 1217-1226.

<sup>103</sup> J.L. Yu and P.E. Savage: “Reaction Pathways in Pentachlorophenol Synthesis. 1. Temperature Programmed Reaction”, *Industrial and Engineering Chemistry Research*, Vol. 43, Issue 17, pp. 5021-5026.

<sup>104</sup> See paras 8.8 and 8.9 of “Report of the Scientific Advisory Board at its Twenty-Third Session, 18 – 22 April 2016 (SAB-23/1 dated 22 April 2016); JT Smith (1966). Chlorination of turpentine. US Patent 3287241 A, 22 November 1966.

<sup>105</sup> See FFM Report on Douma, paras 8.9 and 8.11.

BC precursor  $\alpha$ -pinene<sup>106</sup>) were detected, providing strong evidence that this conifer wood was exposed to chlorine gas. Chlorine gas is the only chemical that, alone, would produce both BC and TCP in conifer wood.<sup>107</sup> However, the expert consulted by the IIT clarified that this had not been reported or studied in literature available at the time of the attack, and the relevant scientific findings only became common knowledge after the Douma incident as a result of the FFM investigation. Dense chlorine gas, 2.5 times heavier than air, could fill low compartments such as basements. This implies that a high concentration of chlorine in the building's basement, despite the latter being located several floors below the roof where the cylinder was found, would be perfectly plausible from a scientific point of view, and fully consistent with both the behaviour expected from chlorine gas and with the FFM findings.

- 6.61 The chlorinated chemical TCP can be detected in all lignified woods after exposure to chlorine.<sup>108</sup> TCP was identified in a number of wood samples collected by the FFM, including pieces of timber on the floor in the room under the cylinder (SDS05), wood fragments from the top of the kitchen door (also on the third floor) (25SDS), and a piece of wood from a partition-frame in the basement (34SDS). The presence of TCP and absence of BC and  $\alpha$ -pinene in these samples indicates that they were broadleaf (deciduous) wood samples that had been exposed to chlorine.

---

<sup>106</sup> See e.g. J. M. Kopaczyk, et al., "*The variability of terpenes in conifers under developmental and environmental stimuli.*" in *Env Exp Botany*, vol. 180 (December 2020) p. 104197.

<sup>107</sup> See references 29-33.

<sup>108</sup> See e.g. P.S. Rajan, C.-L. Chen and J. S. Gratzl, Formation of chloro-organics during chlorine bleaching of softwood kraft pulp. Part 2. Chlorination of pine kraft lignin fractions, *Holzforschung*, vol. 50, issue 2, 1996, pp. 165-174; M. R. Servos (ed.), Environmental fate and effects of pulp and paper - Mill effluents, "*L. Stromberg et al., Effects of internal process changes and external treatment of effluent chemistry*", 1st ed., 1996, pp. 3-19.

**FIGURE 3: ADDITIONAL SAMPLES COLLECTED AT LOCATION 2 CONSIDERED BY THE IIT**



- 6.62 In order to rank the chlorine exposure level in the wooden samples collected by the FFM, one OPCW designated laboratory re-exposed subsamples of the wood to concentrated chlorine gas. The purpose of this experiment was to show how much of the precursor was still remaining in the FFM wood samples. The TCP levels in the re-chlorinated samples were analysed and the data was compared to the TCP levels in the original FFM samples. The re-chlorination resulted in a five-fold increase in TCP levels in high-exposed samples to a 100-fold increase in low-exposed samples.
- 6.63 Based on the results of the experiment, in the context of the evidence obtained, it can be concluded that the wood samples collected from the room under the cylinder and from the partition frame in the basement of the building (both sampled at floor height) were exposed to high concentrations of chlorine gas. The samples collected from the kitchen door on the third floor and from the water tank support in the basement (both sampled at a height of approximately 2 m above floor level) were exposed to a lower level of chlorine gas. The results match the properties of chlorine being a heavier gas than air, thus accumulating at floor level and resulting in a concentration gradient from floor to ceiling.
- 6.64 An electrical copper wire, hanging from the ceiling at Location 2, was also collected by the FFM (27SDS).

**FIGURE 4: ELECTRICAL COPPER WIRE SAMPLED BY THE FFM AT LOCATION 2 ON 21 APRIL 2018 AND SENT OUT FOR ANALYSIS BY THE IIT**



- 6.65 This electrical wire had an acquired green-coloured patina (i.e. the thin layer corrosion formed on the surface of copper items exposed to the environment). It was stored by the FFM with all due precautions according to OPCW procedures in terms of chain of custody and storage. The sample was sent by the IIT to a forensic laboratory with specific capability for the analysis of the composition and morphology of copper patina. The conclusion of the forensic analysis, combined with the assessment of the chemical expert consulted by the IIT, was that the morphology and elemental composition of the patina was consistent with the patina formed on copper wires exposed to chlorine gas and not with the patina formed on copper as a result of natural corrosion or exposure to saline conditions. This is further evidence that chlorine gas was present in the room under the cylinder.

*Conclusions on chemistry-related aspects at Location 2*

- 6.66 The analytical results presented above support the FFM's hypothesis that chlorine gas (i.e. molecular chlorine) was used at Location 2 in Douma on 7 April 2018.
- 6.67 The presence of chlorinated phenols in concrete debris samples further allowed the IIT to rule out that the levels of TCP and TeCP detected in samples from Location 2 were the result of the use of chlorinated phenols as pesticides. This was shown by the lack of TCP and TeCP in the concrete debris sample collected at the street level, including the total absence of such chemicals in the control sample collected 20 m from the building. TeCP is present as a contaminant (5-10%) in PCP pesticides, and applied as an antifungal treatment of wood for outdoor use in contact with soil (e.g. utility poles and cross arms). The presence of TeCP in the concrete debris from a residential building is not consistent with its use as a pesticide for wood protection. Chlorinated phenols (PCP) used as pesticides always contain TeCP as a minor contaminant in PCP. However, PCP was not detected in any sample from Location 2. This data strongly indicates that the TeCP was produced in situ due to the action of chlorine gas.

- 6.68 The identification of the chlorine signature of two chlorinated chemicals, BC and TCP, in a conifer wood sample collected in the basement provides strong evidence of the presence of chlorine gas in the building. The combination of BC and TCP is a strong signature of chlorine-exposed conifer wood.<sup>109</sup> Furthermore, the chlorine marker TCP was identified in three broadleaf (deciduous) wood samples (SDS05, 25SDS, and 34SDS). The ranking of chlorine exposure levels of wood indicates that, at floor level—both in the room under the cylinder and in the basement—higher concentrations of chlorine gas were present as compared to those samples collected at approximately 2 m above floor level.
- 6.69 The analysis of the patina on the electrical copper wire hanging from the ceiling of the room also supported the presence of chlorine gas at Location 2.
- 6.70 The analytical results also point towards the cylinder found on the rooftop of the building as the origin of the chlorine gas released at Location 2. The highly chlorinated phenols TCP and TeCP were identified in samples collected close to the cylinder. The production of TCP, and in particular TeCP from phenolic precursors, requires the presence of a high concentration of chlorine gas.
- 6.71 Furthermore, the gradient of the chlorinated agents—from the highly chlorinated phenols at the aperture and the room under the cylinder, to the low-chlorinated phenols present on the street—is consistent with the behaviour expected from chlorine gas,<sup>110</sup> as well as with the dispersion pattern as identified in the two gas dispersion models considered by the IIT.
- 6.72 The chemical data reviewed and analysed by the IIT points to the conclusion that chlorine gas was released from the cylinder found on the rooftop of Location 2.<sup>111</sup>

#### Location 4 (“cylinder in the bedroom”)

##### *Findings*

- 6.73 The FFM collected a large number of samples of different types at Location 4.
- 6.74 Two fabric samples—from a blanket under the cylinder (04SDS-L4) and a pillow cover on the bed (10SDS-L4)—were collected in the bedroom on the second floor of the building where the cylinder was found. TCP was identified in both samples by an OPCW designated laboratory, which also identified the highly chlorinated phenol TeCP in the sample from the pillow cover on the bed, suggesting that both fabric samples were exposed to a high concentration of chlorine gas.

---

<sup>109</sup> This conclusion is not at odds with the FFM findings (see FFM Report on Douma, paras 8.10 to 8.13). In the relevant section of the FFM Report, the focus was on whether other species of “reactive chlorine” would have produced the BC and TCP. The report rules out the use of phosgene, cyanogen chloride as a single species released at the site. The “chlorine signature” of BC and TCP in conifer wood, reported by the designated laboratory, was not assessed in the FFM Report.

<sup>110</sup> See further below in this section for a comprehensive assessment of the feasibility of mimicking such a behaviour through other chemical agents.

<sup>111</sup> See FFM Report on Douma, para. 9.11.



**FIGURE 5: SAMPLES COLLECTED AT LOCATION 4 CONSIDERED BY THE IIT**



- 6.75 As was the case with TeCP in the concrete samples from Location 2, the most probable explanation for the formation of TeCP in fabric samples collected from Location 4 is the exposure of a phenolic precursor to a high concentration of chlorine gas.
- 6.76 PCP in pesticides has been banned for indoor use globally owing to the well-known carcinogenic effects of dioxin contaminants present in PCP. In addition, the sole presence of TeCP in the absence of PCP in multiple items at the scene is inconsistent with the origin of TeCP as a contaminant in PCP pesticides. Furthermore, in line with the above assessment in relation to Location 2, in the environment of a residential building no metabolic route for chlorinated phenols by aerobic microorganisms would selectively degrade PCP while preserving TeCP. Therefore, the only explanation for the presence of TeCP alone, based on the analytical data, is its production in situ through the action of chlorine gas.
- 6.77 TeCP was also identified by one OPCW designated laboratory in a sample of chips of paint (14SDS-L4) which had been collected by the FFM from the wall behind the bed in the room where the cylinder was found. As discussed above, the presence of TeCP in the sample points to its exposure to a high concentration of chlorine gas.
- 6.78 The FFM also collected a wood sample (06SDS-L4) from the bed under the cylinder in the room. Both BC and TCP were identified in this wood sample by one OPCW designated laboratory.<sup>112</sup> The combined presence of BC and TCP (as well as the conifer-specific BC precursor  $\alpha$ -pinene) provides strong evidence that this conifer wood was exposed to chlorine gas. As highlighted above, chlorine is the only chemical that, alone, will produce both BC and TCP. The re-chlorination experiments performed by an OPCW designated laboratory, showed that this piece of wood was exposed to

<sup>112</sup>

The wood was classified as originating from a conifer tree species based on the identification of  $\alpha$ -pinene in the sample. See e.g. JM Kopaczyk, et al., "The variability of terpenes in conifers under developmental and environmental stimuli." in *Env Exp Botany*, vol. 180 (December 2020), p. 104197.

high concentrations of chlorine gas. The identification of BC was also confirmed by a second OPCW designated laboratory in their analysis of the sample.

*Conclusions on chemistry-related aspects at Location 4*

- 6.79 The identification of the chlorine signature of two chlorinated chemicals, BC and TCP, in a conifer wood sample taken from the bed on the second floor, provides strong evidence of the release of chlorine gas in the building at Location 4. The wood re-chlorination experiment, performed by an OPCW designated laboratory, indicated that a high concentration of chlorine gas was present at the site. The identification of the chlorine signature of two chlorinated chemicals BC and TCP in conifer wood samples from both Location 2 and Location 4 creates a link between the events of release of chlorine gas in the two buildings.
- 6.80 This is in line with the data obtained from the analysis of both the fabric and the paint samples collected close to the bed, in which TCP and TeCP were identified. The identification of TeCP is also indicative of the presence of high concentrations of chlorine gas to enable its formation.
- 6.81 The analytical results also provide solid support to the hypothesis that chlorine gas was released in the bedroom on the second floor of the building at Location 4. The highly chlorinated phenol TeCP was identified in a number of samples collected close to the cylinder. Its formation requires a high concentration of chlorine gas. The conifer wood samples from the bed under the cylinder were also exposed to very high levels of chlorine gas. Taken together, these results point to the conclusion that the cylinder was the origin of the chlorine gas.
- 6.82 The analytical results also allowed the IIT to discard the hypothesis whereby TCP and TeCP may have been present at Location 4 as a result of their use as pesticides. As noted above, TeCP has, in a mixture with PCP, been applied as an antifungal treatment, limited to wood for outdoor use in contact with soil. The sole presence of TeCP and the absence of PCP in samples of fabric and paint from Location 4 is inconsistent with the use of TeCP as a pesticide. This data strongly indicates that TeCP was produced in situ from the exposure of phenolic precursors to chlorine gas.

Assessment of “staging” hypotheses based on chemical data

- 6.83 The IIT has carefully assessed the information provided by States Parties, and has thoroughly pursued the relevant lines of inquiry. In particular, the independent chemist consulted by the IIT has taken into consideration the hypothesis that the incident of 7 April 2018 in Douma may have been “staged” by the placing of unfilled conventional cylinders at both locations, and subsequently the dousing of them with reactive chlorine (such as household bleach products) in order to resemble an area affected by a chlorine gas attack. However, it is important to bear in mind that while chlorine is a gas, bleach is an aqueous liquid that behaves very differently compared to a gas. Therefore, the spread of chlorine gas would be extremely difficult to mimic in a staging activity using bleach.
- 6.84 The IIT has taken into due account the fact that chlorinated organic chemicals can also be produced by the action of reactive chlorine species such as sodium hypochlorite, which is present in household bleach products. However, the “staging” scenario is not supported by the chemical data, as well as in the pattern of how the relative levels of

the chlorinated chemicals are distributed. Furthermore, the practical requirements, the strict planning and the extensive work entailed by a “staging activity” would have made it extremely laborious to be implemented, especially in a conflict-affected area and considering the (at the time) non-availability of scientific information about the BC and TCP production in conifer wood by chlorine gas.

- 6.85 Chlorinated phenols could, theoretically, have been produced through the treatment of concrete blocks (at Location 2) and of different items at the scene (at Location 4) with bleach solution. However, the expert consulted by the IIT determined that, at both locations, it would have been very difficult, if not impossible, to mimic the spread of a gas such as chlorine.
- 6.86 At Location 2, to produce samples aligning to the observed concentration gradient dropping from the highest levels in the room directly under the cylinder to the intermediate concentrations at the crater’s edge on the fourth floor, to the low levels on the street, bleach solutions of different concentrations would have had to be prepared and applied at the appropriate locations. Furthermore, to fabricate the patina on the copper wire hanging from the ceiling would not only have involved assessing which chlorinating agent could have produced that patina, but also the practicalities of accessing the wire in situ.
- 6.87 At Location 4, all of the walls in the room where the cylinder was found would have had to be treated, multiple times, with highly concentrated bleach solutions to mimic the chlorine exposure of paint on the walls. The treatment of all of the (sampled) fabric items in the room, the blanket, pillow, and the pillow cover, together with all other fabric items, would have been required. This process would have likely included the soaking of the fabric in a highly concentrated bleach solution. However, chlorinated phenols would have dissolved in such a solution, due to the high pH. Thus, a staging action involving, for example, the treatment of fabric with bleach solution would probably have removed most of the chlorinated phenols produced in the process, which is at odds with the totality of the chemical data from Location 4.
- 6.88 Furthermore, all of these operations would have had to be performed, at both locations, according to a detailed plan in order to produce the concentration gradient and pattern observed in the results.
- 6.89 The “staging” of chlorine markers found in wood would have been even more arduous. The presence of both BC and TCP in chlorinated conifer wood was not common knowledge at the time of the incident in Douma, not even among scientists. Even if the perpetrators of a hypothetical staging project had had knowledge of the presence of both BC and TCP in chlorinated conifer wood, it would have been difficult to produce the chlorine signature by agents other than chlorine. Such a staging would have required the concerted exposure of the relevant wood items (i.e. the wood support of the water tank at Location 2 and the wood from the bed at Location 4) to both hydrochloric acid and bleach. The acidification of bleach would result in the inevitable production of chlorine gas, but not in sufficient concentrations required to produce the analytical results observed in the samples recovered from the scene. The successful staging of an attack by chlorine gas would have required the following steps: (1) application of one agent; (2) waiting for the agent to react; (3) extensive rinsing; and (4) application of the other agent. This would have been a demanding endeavour (especially considering the

large dimensions of the wood items at both locations). The IIT was unable to identify any evidence, including from open-source information or from the Syrian Arab Republic or other States Parties, that would corroborate that any of the aforementioned staging actions were performed at either location.

- 6.90 Furthermore, it would have been impossible to foresee what samples the FFM inspectors would have collected, and where, at each location. In all of the data resulting from the chemical analysis of the samples collected at both locations, there were no outliers, i.e. no samples displayed a result that was inconsistent with the hypothesis that chlorine gas was released from the cylinders found at both locations.
- 6.91 Finally, the IIT has carefully reviewed the chemical data relating to a warehouse (GPS coordinates: 33° 34' 24", E 36° 23' 41.1) suspected by the authorities of the Syrian Arab Republic of producing chemical weapons in Douma. The FFM visited the warehouse on 27 April 2018 at the request of the Syrian Arab Republic,<sup>113</sup> and identified a number of chemicals linked to the production of explosives.<sup>114</sup> A sample was sent to two OPCW designated laboratories, both of which detected hexamine of high purity.<sup>115</sup> The FFM concluded that hexamine, as well as a number of other chemicals present in the warehouse, were linked to the production of explosives.<sup>116</sup> It further stated that no indication of the production of chemical warfare agents was observed at the sites.<sup>117</sup> Based on the assessment of the relevant analytical data and of the FFM Report, the independent chemist consulted by the IIT supported the FFM's conclusions.<sup>118</sup>

### **Symptoms of affected persons**

- 6.92 Chlorine is a toxic chemical with low persistency and a variable rate of action. While chlorine has several legitimate uses, gaseous chlorine is considered to be poisonous and is classified as a pulmonary irritant. The determination of its toxicity is dependent on the duration and dose of exposure. As noted above,<sup>119</sup> chlorine gas is typically 2.5 times heavier than air, and therefore, following dispersion, tends to accumulate in low-lying areas.
- 6.93 Exposure to chlorine gas acts upon multiple body systems: the skin and mucous membranes, the gastrointestinal tract and the respiratory system, where it is absorbed into the lungs. When chlorine makes contact with mucosal surfaces in the nasal,

---

<sup>113</sup> See Note Verbale No. 43 (dated 20 April 2018) from the Permanent Mission of the Syrian Arab Republic to the OPCW.

<sup>114</sup> See FFM Report on Douma, Annex 8, paras 4 and 5.

<sup>115</sup> See FFM Report on Douma, Annex 5, p. 50.

<sup>116</sup> See FFM Report on Douma, Annex 8, para. 11.

<sup>117</sup> See FFM Report on Douma, para. 8.39.

<sup>118</sup> It should be noted, though, that the mandate of the IIT is "to identify and report on all information potentially relevant to the origin of those chemical weapons in those instances in which the OPCW Fact-Finding Mission in Syria determines or has determined that use or likely use occurred". Since that was not the case for the said warehouse, the latter does not represent a location of interest to the IIT for the purpose of the present report.

<sup>119</sup> See "Chemical analyses" section above.

tracheal, and respiratory areas, moisture from those surfaces leads to the formation of hypochlorous acid and hydrochloric acid.<sup>120</sup>

- 6.94 The concentration of the toxic chemical and the length of exposure to it are key determining factors in the fatality of a person exposed to chlorine gas.<sup>121</sup>
- 6.95 For its analysis, the IIT assessed the accounts received in relation to the location of the victims, the symptoms they described, the communications of the “spotters” in relation to the aircraft activity in the area that day,<sup>122</sup> the accounts and movements of first responders, as well as the distance between the buildings at Location 2 and 4 and the medical facility to which the victims were transported.
- 6.96 The IIT consulted several specialists and requested an independent expert (toxicologist) not involved in previous assessments of the incident to make their own evaluation of the reported symptoms. In order to minimise possible bias and protect confidentiality, the IIT provided the expert with anonymised accounts and data from 55 individuals interviewed by either the FFM or by the IIT, including affected persons and others who were present at the scene or otherwise involved in the rescue operations in the hours after the incident.
- 6.97 Both the expert and the specialists consulted by the IIT assessed the FFM Report on Douma, videos, photographs, and information provided by witnesses—including medical personnel—on the symptoms and treatment of the affected persons involved in the incident of 7 April 2018, as well as additional materials available in open sources. Following the review of relevant materials and medical literature, the toxicologist independently assessed the anonymised witness statements (obtained from affected persons or other eyewitnesses to the symptoms) against the symptoms that could be expected from chlorine exposure. They also considered imagery related to the treatment received by the victims.

#### Location 2 (“cylinder on the roof”)

- 6.98 The IIT took note of the information from witnesses stating that they had been affected by chlorine gas while at the residential building on whose rooftop the cylinder was found. The IIT also considered the accounts of rescuers who provided the victims first aid and brought them to Rif Dimashq Specialized Hospital (also known as “Point 1”, or Location 1 in the FFM Report on Douma), located about 200 m from Location 2, for further treatment; some of these rescuers also reported having been affected after entering the building or coming into contact with the victims.

---

<sup>120</sup> See e.g. Fifi N.M Elwekeel, Xinguang Cui, Antar M.M Abdala, “*Effects of chlorine particle concentration on the human airway*”, in *Journal of Nanoparticle Research*, vol. 24 article 105 (May 2022) in National Library of Medicine, available at: <https://www.ncbi.nlm.nih.gov/pmc/articles/PMC9119845/>; A. Morim, G. T. Guldner (eds), “Chlorine Gas Toxicity”, National Library of Medicine, (last updated on 27 June 2022), available at: <https://www.ncbi.nlm.nih.gov/books/NBK537213/>.

<sup>121</sup> See e.g. C. W. White and J. G. Martin, “*Chlorine Gas Inhalation Human Clinical Evidence of Toxicity and Experience in Animal Models*”, in *Proc Am Thorac Soc*, vol. 7 (4), (July 2010), pp. 257-263.

<sup>122</sup> See para. 5.9 in the Second IIT Report.

- 6.99 Symptoms described by affected persons, rescuers, and treating medical personnel included shortness of breath, coughing, suffocation, dizziness, and skin irritation. In addition to the symptoms reported, several witnesses and victims in the building at the time in which the incident occurred reported a distinct and pungent smell of chlorine.<sup>123</sup>
- 6.100 Medical personnel further recounted to the IIT that patients started to arrive at “Point 1” between approximately 19:30 and 19:45—both independently and carried by rescuers—through the tunnel leading to the medical facility. They added that several individuals exhibited signs of respiratory distress including coughing, wheezing, shortness of breath, unconsciousness and, in several cases, oral secretions. In particular, medical personnel noted a distinct smell of chlorine on the affected individuals. Upon arrival, those with severe symptoms were placed in the intensive care unit, other affected individuals were treated with atropine, salbutamol via an inhaler or nebuliser, and stabilised before being sent home. In particular, medical personnel recounted that over 100 cases came to “Point 1”, the majority of which only experienced mild symptoms.
- 6.101 The IIT assessed information from several sources, including witness and other sources of information, which indicated that at least 43 persons—including 7 men, 17 women, 9 boys and 10 girls—died as a result of prolonged exposure to high concentrations of chlorine gas at Location 2. The IIT assessed witness accounts received in relation to the location of both the victims and the fatalities, the symptoms described, the chemical analyses conducted by the FFM, as well as relevant videos and pictures.

**FIGURE 6: IMAGES SHOWING SYMPTOMS: PERSONS WHO DIED AS A CONSEQUENCE OF BEING EXPOSED TO CHLORINE (SOURCE: OPEN SOURCE)**

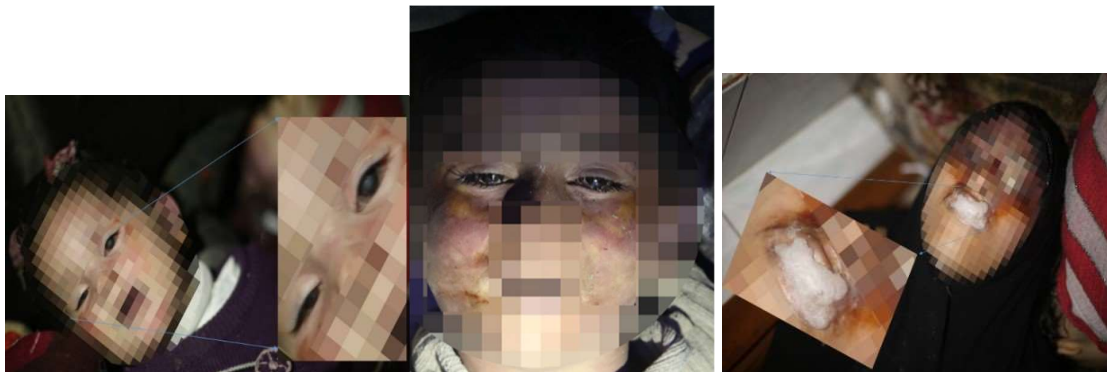

- 6.102 The IIT notes that witnesses recounted how some affected individuals, unaware that the source of the chlorine was on the roof, attempted to move away from the building’s basement and to higher floors, as was the common protocol following chemical attacks. This practice has been highlighted in multiple reports from the conflict in the Syrian Arab Republic,<sup>124</sup> including an FFM Report stating that a message had been conveyed

<sup>123</sup> See FFM Report on Douma, paras 8.59 and 8.64.

<sup>124</sup> Independent International Commission of Inquiry on the Syrian Arab Republic, “The Siege and Recapture of eastern Ghouta”, 20 June 2018, A/HRC/38/CRP.3, para. 31.

to the public on hand-held radios to escape to higher ground rather than stay in the basement in the event of a chemical attack.<sup>125</sup>

- 6.103 A crucial element in establishing why some affected individuals remained inside the basement and others did not is the increasingly intense bombardment experienced by residents of Douma on 7 April 2018, when multiple conventional sorties (i.e. airstrikes carried out by aircraft that did not carry a chemical payload) targeted the city. In the event of a conventional airstrike, the advice to the civilian population would have been to remain under hard cover in a location such as the basement at Location 2. Witnesses and affected individuals recounted how other casualties who remained inside the basement or buildings managed to reach the tunnel leading to the hospital while others reportedly collapsed on the way.
- 6.104 Moreover, the IIT notes that affected persons who survived were physically able to reach the roof or went away from the tunnel, leading to the hospital, while others who attempted to escape the basement did not. The IIT assess that it is likely that the recommended protocol during chemical attacks “to head to higher ground” is why the majority of the fatalities are observed on the first and second floors and on the stairs. Thus, on the basis of information obtained by the IIT, including the distribution of the fatalities, contextual information on protocol during chemical and conventional attacks, expert reports from specialised institutes in gas dispersion, and the reported symptoms, there are reasonable grounds to believe that the high number of fatalities observed in the building at Location 2 were as a result of severe symptoms experienced on the floors below the cylinder on the roof.
- 6.105 Despite some minor variances in witnesses’ recollection of events, the IIT assessed the accounts, overall, to be consistent. Careful analysis of imagery and videos taken in the aftermath of the incident show a number of affected persons at Location 2 exhibiting clear signs of corneal opacity, discoloration of the skin, white/off-white foam-like oral and nasal secretions and miosis. Alongside these symptoms, rigor mortis was observed in persons being carried out of the building, hours after the incident took place. In addition, the IIT notes that some of the secretions observed were also pinkish/brown in colour, which is likely due to a combination of blood-tinged sputum and changes in its colour due to the time elapsed between when the exposure occurred and when the fatalities were documented. Moreover, the specialists consulted by the IIT confirmed that the reported and observed symptoms of oral opacity are typically caused by corneal burns as a result of exposure to a high concentration of chlorine gas.<sup>126</sup>
- 6.106 The IIT also notes that as chlorine gas reacts with the cells and moisture in the gastrointestinal tract to produce acids, that reaction also leads to the oral and nasal secretion of a foam-like substance, which may or may not have a pink tint, believed to be blood.<sup>127</sup>

---

<sup>125</sup> See para. 5.66 of the “Third Report of the OPCW Fact-Finding Mission in Syria” (S/1230/2014, dated 18 December 2014).

<sup>126</sup> See e.g. A. Morim, G. T. Guldner (eds.), “Chlorine Gas Toxicity”, National Library of Medicine, (last updated on 27 June 2022), available at <https://www.ncbi.nlm.nih.gov/books/NBK537213/>.

<sup>127</sup> See e.g. C. W. White and J. G. Martin (2010), “Chlorine Gas Inhalation Human Clinical Evidence of Toxicity and Experience in Animal Models”, in Proc Am Thorac Soc, Vol. 7 (4), (July 2010), pp. 257-263.

- 6.107 Finally, the IIT obtained information indicating that the concentration of chlorine released at Location 2 in Douma on 7 April 2018 was at least 1,000 ppm. The IIT notes that exposure to higher concentrations of chlorine gas increases the severity of symptoms, in exposure to low and or moderate concentrations of chlorine gas (25 to 50 ppm), pulmonary oedema, presents within three-four hours, while following exposure to high concentrations of chlorine gas (greater than 50 ppm), there is an abrupt and rapid onset of respiratory symptoms, and in concentrations over 400 ppm, fatality occurs within minutes. This is consistent with those observed in Douma on 7 April 2018.<sup>128</sup>
- 6.108 Following the review and verification of the relevant material, the toxicologist reached the conclusion that the accounts of the victims and medical personnel are consistent with the rapid release of a high dosage of chlorine gas, which led to the rapid and high fatality rate seen at Location 2.

*Gas dispersion modelling*

- 6.109 While the symptoms of the victims are consistent with chlorine exposure, the IIT considered it useful to assess possible chlorine gas dispersion from the cylinder found at Location 2, where the majority of fatalities were reported. The IIT obtained and reviewed two sets of data and visual representation(s) of gas dispersion modelling independently elaborated on the basis of several parameters, including locations of the crater, prevailing weather conditions, as well as variations in the filling capacity of the cylinder and of the dispersion rate of the gas.
- 6.110 In all simulations, the same amount of chlorine was released at the same rate and a number of variables were taken into consideration, such as the state of the windows and doors, the orientation of the cylinder, and meteorological and surface conditions at the time when the incident occurred; as a result multiple scenarios were run with the varying parameters.
- 6.111 The IIT notes that all models indicate that within three minutes of the release of chlorine from the cylinder, all floors within the building would have exceeded a concentration of chlorine which would lead to occupant death, noting that within 60 seconds the concentration of chlorine on the second floor would have led to occupant death. Furthermore, as chlorine is heavier than air, it would be expected to sink and, as a result, disperse in higher quantities below the point of impact on the roof, spreading to the floors below.<sup>129</sup>
- 6.112 The IIT also noted a second scenario in the dispersion assessment which examined possible escape routes at the time of the attack. In the case of the cylinder found on the rooftop at Location 2, the model indicates that upon the release of chlorine from the cylinder into the building, the dispersion was so rapid that it obstructed the only possible escape route from the apartments via the stairwell. In addition, the IIT notes that approximately 20 seconds after the release of chlorine, escape from the apartments on the third floor was almost certainly no longer possible and after 60 seconds, escape

---

<sup>128</sup> DOA 1993 Pathology of Chlorine exposure leading to death. “Postmortem findings included [...] mottled appearance on lung surface with scattered areas of emphysema, pleural hemorrhage, perivascular edema, [...] frothy fluid filling the trachea and bronchi” Centers for Disease Control, available at: <https://www.atsdr.cdc.gov/toxprofiles/tp172.pdf>.

<sup>129</sup> As also noted in “Chemical analyses” section above.



from the apartments on the second floor was almost certainly no longer possible either. The specialists' assessment that all exit routes on the third and second floor were no longer accessible without exposure to a high and lethal volume of chlorine gas are consistent with the rapid onset of symptoms which led to the fatalities recorded on the stairs and landings, as reported by witnesses and observed in videos and pictures from the incident.

- 6.113 The decrease in concentration occurred over the following 60 minutes, whereby the chlorine concentration decreased to zero in almost all exit points except the entrance, where the concentration remained low, but not lethal. This is consistent with reports of first responders accessing the building without experiencing life-threatening symptoms, after 60 minutes had passed.
- 6.114 In conclusion, the gas dispersion models analysed by the IIT indicate that the accounts of the witnesses in relation to the effect of chlorine gas on the victims and the rapidity with which the symptoms began at Location 2 are indeed reliable, and that there are reasonable grounds to conclude that those persons were affected by chlorine gas used as a weapon.

#### Location 4 (“cylinder in the bedroom”)

- 6.115 At Location 4, witnesses who first arrived at the scene (around midnight on the night of 7 to 8 April and in the morning of 8 April, respectively) reported (comparatively mild) symptoms, as well as a strong odour similar to chlorine. The absence of severe symptoms and fatalities at Location 4—compared to those reported at Location 2 and in the surrounding area—are a direct result of the different damage sustained to the cylinders,<sup>130</sup> the positions in which they landed, the manner in which their contents were released and, most notably, the lack of persons in the building at Location 4 at the time in which the incident occurred.<sup>131</sup> As noted in the “Assessment of remnants” section below,<sup>132</sup> the valve of the cylinder found at Location 4 was largely intact. That is consistent with a slow and steady release of chlorine gas from the cylinder<sup>133</sup> (also reported by witnesses who had access to scene in the aftermath of the incident), as opposed to the cylinder found at Location 2, whose valve ruptured, indicating a sudden and substantial release of chlorine gas, which is consistent with the severe symptoms experienced by those who were in the building at the time of the attack.

#### Investigation of alternative scenarios

- 6.116 In view of the alternative scenarios pursued during its investigations, the IIT assessed whether the symptoms reported may have been a direct result of a chemical agent other than chlorine. In particular, the IIT assessed if exhibited symptoms such as contorted limbs and involuntary urination/defecation could be due to a chemical or nerve agent, other than chlorine. In that respect, the IIT obtained information which showed that these symptoms are consistent with hypoxia-induced seizure activity. In addition, the

---

<sup>130</sup> See “Assessment of remnants” section below.

<sup>131</sup> Local sources explained that the residential building was empty at the time of the incident, since its occupants had left because of the heavy shelling in the area. The lack of a basement in the building in which they could take shelter reportedly contributed to such a decision.

<sup>132</sup> See “Assessment of remnants” section below.

<sup>133</sup> See FFM Report on Douma, para. 8.69.

expert toxicologist came to the conclusion<sup>134</sup> that the chemistry analytical data underlying the FFM Report on Douma, which included blood samples, does not support evidence of any types of chemical compounds except for chlorine, adding that the laboratory data only supports chlorine exposure.

- 6.117 In addition, the IIT assessed an alternative scenario in which the fatalities had been caused elsewhere and subsequently moved to Location 2 in an attempt to “stage” an attack.<sup>135</sup> Neither witnesses nor medical personnel recount observing blunt force trauma or penetrating trauma in any of the fatalities. In addition, the IIT, in its assessment of verified videos and images from Location 2, did not observe any signs of blunt force trauma or penetrating trauma among the fatalities. Furthermore, fully established rigor mortis was observed in fatalities being carried out of Location 2 in the early hours of 8 April 2018, indicating that the time since death was no more than approximately 9 to 16 hours earlier.
- 6.118 Douma was subject to dozens of sorties on the 7 April 2018, leading to the presence of excess “dust” in the air as a result of debris from airstrike damage to buildings.<sup>136</sup> The expert toxicologist noted that mild cases in the emergency room of patients experiencing symptoms of respiratory distress may have been a result of “dust” caused by airstrike debris. In addition, the respiratory strain due to the “dust” dispersed over the course of the day is likely to have exacerbated the severe symptoms experienced in the fatalities and persons affected by the chlorine exposure. However, symptoms observed in affected persons, including miosis, skin discoloration, and oral and nasal foam-like secretions, are unlikely to have been as a direct result of “dust” inhalation.
- 6.119 Symptoms experienced as a result of chlorine exposure are diverse, non-specific, and dependent on concentration and duration of exposure, and as a result may not be diagnostically conclusive when assessed in isolation. Therefore, the IIT notes that while none of the symptoms described by victims and medical personnel are exclusive to chlorine exposure, when they are taken into consideration alongside chemical samples, clinical data, the distribution of fatalities, gas dispersion, ballistics, and the characteristics of the substance as described by survivors of the incident that occurred in Douma on 7 April 2018, these symptoms are consistent with those originating from chlorine gas exposure at high concentrations.

### Conclusions

- 6.120 In conclusion, the toxicology assessment, based among others on data provided by independent specialised institutions and scientific literature, indicates that the accounts of witnesses (including medical personnel that attended to the affected persons) in relation to the effect of chlorine gas on the victims are reliable, and that those persons were affected by chlorine gas used as a weapon.

---

<sup>134</sup> Consistent with findings in “Chemical analyses” section above.

<sup>135</sup> itvX, “UK helped fake chemical attack in Douma, Syria official tells ITV news”, 22 April 2018, available at: [itv.com/news/2018-04-22/Syrian-official-accuses-uk-of-helping-to-fake-chemical-attack-in-Douma](http://itv.com/news/2018-04-22/Syrian-official-accuses-uk-of-helping-to-fake-chemical-attack-in-Douma).

<sup>136</sup> The IIT notes in the meteorological section that no dust storms, also referred to as sandstorms, were recorded on 7 April 2018. Cloud coverage over Douma was 28% TCC, indicating that no dust storm was present. No other sources assessed by the IIT indicate that a dust storm occurred over the Syrian Arab Republic on the day of the incident.

### Assessment of remnants

- 6.121 As noted above,<sup>137</sup> in its report on the Douma incident the FFM assessed that it was “possible”<sup>138</sup> that “two yellow industrial cylinders”<sup>139</sup> found at the two sites of alleged use of toxic chemicals “were the source of the substances containing reactive chlorine.”<sup>140</sup>
- 6.122 The IIT consulted three munition specialists to further inform its assessment as to whether the cylinders found at both locations could be identified as the source of reactive chlorine and to make a determination as to the method of their delivery.
- 6.123 As highlighted above,<sup>141</sup> and as was the case with both its First and its Second Reports, the IIT was unable to access the relevant sites of the incident in the Syrian Arab Republic. As also recalled above,<sup>142</sup> on 9 July 2021 the Syrian Arab Republic informed the Secretariat of the loss of “the two chlorine cylinders related to the alleged Douma incident”, reportedly as a result of an airstrike carried out on 8 June 2021 on the “Al-Nasiriyah 1” site.<sup>143</sup>
- 6.124 Therefore, the IIT requested the munition specialists to engage in a thorough study of imagery of the location of both cylinders and their appearance, together with the munitions’ remnants in and around the relevant apertures. The specialists consulted by the IIT considered video and photographic footage taken at the two locations (including those taken by the FFM) and open-source materials; samples collected and measurements taken by the FFM; results of cylinder drop trials;<sup>144</sup> and assessments provided by other experts and sources.
- 6.125 According to standard practice, the authenticity of images and their content was checked and analysed through different means: witnesses were interviewed with regard to the recording of videos as well as to the locations and individuals shown; images from various sources were compared; geolocation analysis was conducted; and metadata extraction was performed by a forensic institute. It was the combination, consistency, and corroboration of different sources of information that provided the necessary degree of certainty in respect to the reliability of the imagery, and not reliance on individual pieces of information.

### Location 2 (“cylinder on the roof”)

- 6.126 At Location 2, a yellow industrial-type cylinder with visible damage and impact deformations was found on the rooftop of a residential building.<sup>145</sup>

---

<sup>137</sup> See “The findings of the Fact-Finding Mission” section above.

<sup>138</sup> FFM Report on Douma, para. 9.11.

<sup>139</sup> FFM Report on Douma, para. 9.7.

<sup>140</sup> FFM Report on Douma, para. 9.11.

<sup>141</sup> See “Approach and Challenges in the Investigation” section above.

<sup>142</sup> See “Approach and Challenges in the Investigation” section above.

<sup>143</sup> Note Verbale No. 68 by the Permanent Mission of the Syrian Arab Republic to the OPCW, dated 9 July 2021.

<sup>144</sup> See “Approach and Challenges in the Investigation” section above.

<sup>145</sup> See “Chemical analyses” section above.

- 6.127 The length of the cylinder, as measured by the FFM when visiting the scene on 21 April 2018,<sup>146</sup> is approximately 1,400 mm, with a body diameter of 350 mm and a base diameter of 330 mm. The measured size and shape of the cylinder are consistent with a capacity of between 100 and 120 litres.

**FIGURE 7: THE LENGTH OF THE CYLINDER FOUND AT LOCATION 2 AS MEASURED BY THE FFM ON 21 APRIL 2018 (SOURCE: FFM)**



---

<sup>146</sup> See FFM Report on Douma, para. 8.21.

**FIGURE 8: BASE DIAMETER OF THE CYLINDER FOUND AT LOCATION 2 AS MEASURED BY THE FFM ON 21 APRIL 2018. THE DIMENSIONS OF THE CYLINDER CORRESPOND TO THOSE OF THE CYLINDER USED IN THE CHEMICAL ATTACK ON SARAQIB ON 4 FEBRUARY 2018 (SOURCE: FFM)**



- 6.128 There is a neck (valve well) at the top of the cylinder. The valve appears to be sheared off, and the broken valve's body is still screwed into the cylinder's opening. A remnant of the valve body is visible in pictures below, which indicates that the valve "tap" broke off as a result of impact. This, in turn, would be at odds with the manual unscrewing of the valve.
- 6.129 The external threads on the cylinder collar (visible in pictures below and marked by a yellow arrow) are normally used to attach a valve protection cap to the protruding valve. That safety feature helps to prevent any damage to the valve in the event that the cylinder should accidentally fall during its storage, transportation, or handling. However, no valve protection cap is visible from the images taken at the scene. Furthermore, no damage is visible on the external threads, as would have been expected had the cylinder impacted with a valve protection cap attached. The lack of a valve protection cap would facilitate the release of the contents of the cylinder, which could provide an indication of its intentional weaponisation.

**FIGURE 9: ON THE LEFT: YELLOW INDUSTRIAL CYLINDERS WITH VALVE PROTECTION CAPS ATTACHED, MARKED WITH A YELLOW SQUARE. ON THE RIGHT: CYLINDER FOUND AT LOCATION 2 WITH EXTERNAL THREADS SHOWING NO VISIBLE MECHANICAL DAMAGE. (SOURCE: OPCW AND FFM)**





**FIGURE 10: LARGER IMAGE (SOURCE: FFM): INDUSTRIAL CYLINDER FOUND AT LOCATION 2 WITH VISIBLE VALVE WELL. THE BROKEN VALVE'S BODY (PART OF WHICH IS STILL SCREWED IN THE CYLINDER OPENING) IS MARKED WITH A RED ARROW, WHILE THE THREADS USED FOR ATTACHING THE VALVE PROTECTION CAP ARE MARKED WITH A YELLOW ARROW. SIMILAR DAMAGE OF THE VALVE (MARKED WITH A RED ARROW) IS VISIBLE ON CYLINDERS USED IN PREVIOUSLY DOCUMENTED INCIDENTS OF USE OF CHLORINE AS A CHEMICAL WEAPON E.G. IN KAFR ZEITA, 1 OCTOBER 2016<sup>147</sup> (SEE PHOTOGRAPH IN BLUE SQUARE) AND SARAQIB, 4 FEBRUARY 2018 (SEE PHOTOGRAPH IN RED SQUARE).<sup>148</sup>**



6.130 As noted above, the cylinder is yellow-coloured, which some industrial standards associate with a chlorine content. However, the colour of the cylinder alone cannot be conclusively relied upon to identify the substance stored in it.

<sup>147</sup> Note by the Secretariat “Report of the OPCW Fact-Finding Mission in Syria Regarding the Incident of the Alleged Use of Chemicals as a Weapon in Kafr Zeita, Syrian Arab Republic 1 October 2016”, S/2020/2022 (31 January 2022) paras 1.11 and 8.15.

<sup>148</sup> Second IIT Report, para. 6.21.

- 6.131 As noted below,<sup>149</sup> similar industrial cylinders were observed in previous incidents of use of chlorine as a chemical weapon in the Syrian Arab Republic, including in Ltamenah (25 March 2017) and Saraqib (4 February 2018), both reported on by the IIT.<sup>150</sup>
- 6.132 There are visible deformations and blackened soot on one side of the cylinder. According to the FFM Report, fire was lit after the incident, reportedly to detoxify the chemical from the room under the aperture.<sup>151</sup> The specialists consulted by the IIT concurred with the FFM's assessment that the blackened soot visible on one side of the top section of the cylinder most likely resulted from the smoke originating from the fire. This fire was lit in the room located directly below the aperture under the cylinder, and vented through the opening in the ceiling. Soot deposits are also visible on the walls of the same room and close to the reported fire location, on the ceiling, as well as on the rim of the aperture (see pictures below in this section and further below in this section).<sup>152</sup> This indicates that the fire occurred after the aperture was created.

---

<sup>149</sup> See "Distinctive features of the cylinders, pattern of use, and possible scenarios" subsection below.

<sup>150</sup> See First IIT Report, paras 8.25-8.29; and Second IIT Report, paras 6.19-6.25.

<sup>151</sup> See FFM Report on Douma, Annex 6, para. 9.

<sup>152</sup> It should be noted that, in one of the earliest images of the scene (taken on 8 April 2018), the side of the cylinder displaying the blackening soot is facing downwards, while in the images taken later (e.g. on 11 April 2018) the side of the cylinder with apparent blackening soot is facing upwards. This indicates that the cylinder was rotated between the dates on which the relevant pictures were taken. See also further below in this section.



**FIGURE 11: VISIBLE CRATER ON THE ROOFTOP OF LOCATION 2 PHOTOGRAPHED FROM THE ROOM DIRECTLY BELOW. PART OF THE YELLOW INDUSTRIAL CYLINDER (MARKED WITH A GREEN ARROW) AND DEPOSITS OF BLACKENING SOOT ON BOTH THE CEILING AND THE WALLS ARE VISIBLE. NO FRAGMENTATION DAMAGE PATTERN CONSISTENT WITH EXPLOSION IS VISIBLE ON THE WALLS.**



6.133 Also visible on the cylinder's body is the damage pattern that appears to correspond to the grid pattern of the metal mesh present on the rooftop (which lies next to the cylinder). This is consistent with the cylinder having hit the mesh at a considerable

velocity, which in turn, would be at odds with the cylinder having been manually placed on the rooftop.<sup>153</sup>

**FIGURE 12: VISIBLE SQUARE-PATTERNED DAMAGE ON THE CYLINDER'S BODY RESEMBLING THE GRID PATTERN OF THE METAL MESH LOCATED ON THE ROOFTOP. (SOURCE: FFM)**



- 6.134 The IIT has reviewed a video taken in the immediate aftermath of the incident. In the video, the top part of the cylinder protruding through the aperture appears to be white-coloured. In images taken the following day, that is on 8 April 2018, the cylinder appears distinctly yellow.
- 6.135 Based on the combination of munitions and chemistry findings, the IIT assesses that the white colouration visible on the cylinder could be explained as the formation of frost on its surface.<sup>154</sup> This, in turn, would be consistent with the auto-refrigeration phenomenon having occurred upon the rapid release of a liquefied gas from the cylinder. The auto-refrigeration phenomenon (also known as “adiabatic cooling” in thermodynamics) is common to liquefied compressed gasses.<sup>155</sup> It refers to the formation of a liquid condensation on the cylinder caused by the temperature drop due to the rapid release of gas. Therefore, the photo and video footage reviewed by the IIT may indicate that the cylinder found at Location 2 had frozen condensate on its exterior shortly after it was found, but lacked this “frost” the following day.

---

<sup>153</sup> See “Assessment of the impact and delivery of the munitions” section below.

<sup>154</sup> See “Chemical Analyses” section above.

<sup>155</sup> See e.g. Francis Brown, Auto-refrigeration: When Bad things Happen to Good Pressure Vessels, available at: [Nationalboard.org/index.aspx?pageID=164&ID=249](http://Nationalboard.org/index.aspx?pageID=164&ID=249).

- 6.136 The dendritic pale-grey pattern of what appear to be dried up condensation droplets on the cylinder (observed in a picture taken on 9 April 2018) is consistent with moisture mixed with concrete dust, cement, or a similar medium. This may have been caused by the thawing of the frost formed on the cylinder, and thus further corroborates that a liquefied gas was rapidly released from the cylinder.

**FIGURE 13: THE PATTERN OF DRIED-UP CONDENSATION DROPLETS IS MARKED BY A YELLOW SQUARE (SOURCE: FFM)**



- 6.137 Videos and pictures received and authenticated by the IIT also show a deformed and damaged metal structure (“cradle”) near the cylinder, as well as a number of metal parts located in the vicinity of the aperture on the rooftop. These include bolts that are visible in pictures taken at the scene. The munitions specialists consulted by the IIT notes that, when industrial cylinders were documented in the Syrian conflict as being fitted with metal cradles, the cradles were secured to the cylinders by bolts. Therefore, the presence of bolts at the scene supports the conclusion that the metal structure was attached to the cylinder, but detached upon impact. An analogous detachment was observed in other incidents involving similar devices (i.e. in Kafr Zeita on 1 October 2016; Ltamenah on 25 March 2017; and Saraqib on 4 February 2018).



**FIGURE 14: DETACHED CRADLE VISIBLE NEXT TO THE CYLINDER AT LOCATION 2 (SOURCE: FFM)**



- 6.138 Metal parts of the cradle seem to have been heavily corroded, which is consistent with exposure to oxidants, such as chlorine.
- 6.139 The cradle presents several elements that are consistent with similar metal structures found at the scenes of previous incidents of use of chemical weapons that involved industrial cylinders filled with chlorine.<sup>156</sup>
- 6.140 For instance, a circular metal plate and a circular metal disc were recovered by the FFM on 24 April 2018 on the rooftop where the cylinder had been found. The circular metal plate (collected by the FFM as sample 16SDS, and visible in Figure 9) consists of a 20-mm thick dome-shaped plate with a circular hole in it. A thin-walled metal pipe is inserted through the hole. Several small welding spots are visible on both the inner side and the rim of the domed plate. A detailed image of the circular metal plate is given below.

<sup>156</sup>

Similar cylinders and cradles were observed in the incident in Saraqib (4 February 2018) as reported by the IIT in its Second Report, paras 6.22-6.25. No complete cradle was observed in the Ltamenah incident (25 March 2017). However, the cylinder had markings which indicated the initial presence of such a cradle, and parts of it were identified at the scene. See First IIT Report, para. 7.28.

**FIGURE 15: LARGE CIRCULAR METAL PLATE, COLLECTED BY THE FFM AT LOCATION 2 ON 21 APRIL 2018 AS SAMPLE 16SDS, AND MEASURED BY THE IIT MUNITION SPECIALISTS ON 4 MARCH 2022. (SOURCE: IIT)**

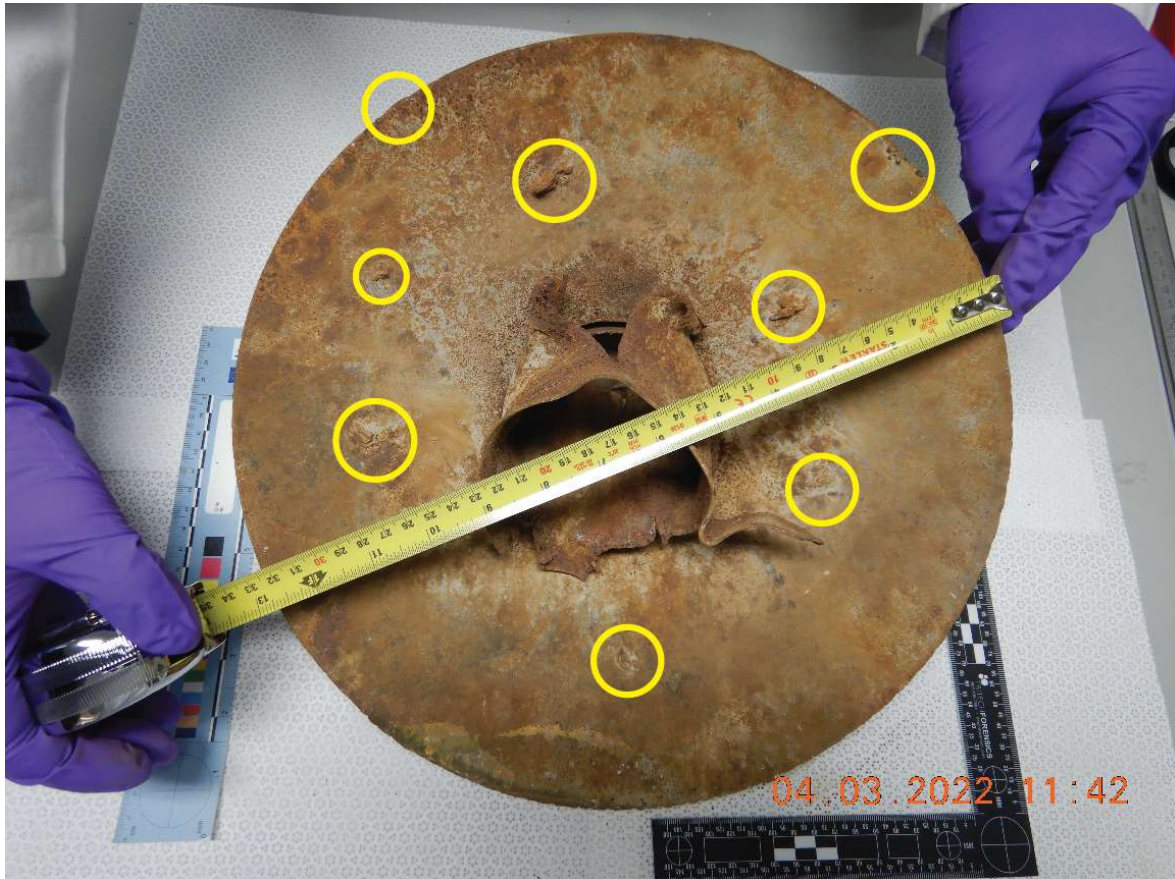

6.141 The circular metal plate is similar (i.e. material, shape, dimensions) to the circular metal plate (sample SDS12) discovered and collected in Saraqib (incident of 4 February 2018) at the location identified as Crater 2 in the Second IIT Report.<sup>157</sup> Welds similar to the one visible on 16SDS were also observed on the concave side of the plate and edges of SDS12.<sup>158</sup> A similar circular metal plate was also observed in the incident of use of chemical weapons which occurred in Ltamenah on 25 March 2017, as documented in the First IIT Report.

<sup>157</sup> Second IIT Report, para. 6.24.

<sup>158</sup> Sample SDS12 measurements were performed by the IIT at the OPCW Laboratory on 11 February 2021.

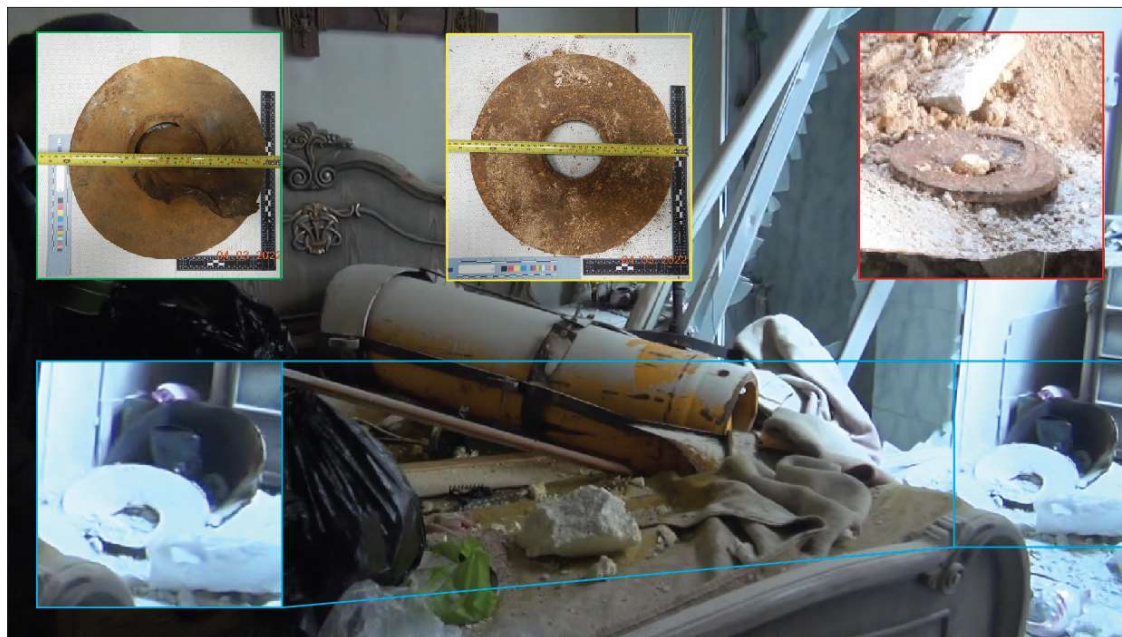

**FIGURE 16: COMPARISON OF METAL FRAGMENTS RECOVERED IN LTAMENAH (25 MARCH 2017), SARAQIB (4 FEBRUARY 2018), AND DOUMA (7 APRIL 2018)**



6.142 Small circular metal discs bearing close resemblance to the ones recovered in Douma at Location 2 (e.g. sample 12SDS, examined by the IIT munitions specialists and visible below) were also observed in relation to the Saraqib incident near Crater 2<sup>159</sup>

**FIGURE 17: METAL CIRCULAR DISC OBSERVED IN THE VICINITY OF CRATER 2 IN THE SARAQIB INCIDENT (MARKED IN YELLOW). ALSO IN THE VICINITY OF CRATER 2, ANOTHER SIMILAR METAL CIRCULAR DISC WAS FOUND (MARKED IN RED). THE SMALL METAL DISC COLLECTED BY THE FFM AT LOCATION 2 IN DOUMA AS SAMPLE 12SDS IS MARKED IN BLUE.**



- 6.143 When chlorine gas reacts with the moisture in the air, it forms hypochlorous acid (HCl) and hydrochloric acid (HOCl) ( $\text{Cl}_2 + \text{H}_2\text{O} \rightarrow \text{HCl} + \text{HClO}$ ), both of which are highly corrosive to steel and other metals.<sup>160</sup>
- 6.144 Therefore, the heavy corrosion observed on the cradle is consistent with a chlorine release from the cylinder. It should be noted that the corrosion seen on the cradle as well as on other metal objects on the rooftop is not incompatible with chlorine being heavier than air<sup>161</sup> and sinking down the aperture in the rooftop. Once liquefied compressed chlorine is released rapidly from a cylinder's valve, a cloud of chlorine gas would form and surround the cylinder. This is consistent with the presence of chlorinated phenols at the edge of the aperture found at Location 2,<sup>162</sup> and with the exposure of the rooftop to chlorine gas.
- 6.145 On the lower parts of the rooftop walls, there is no visible impact from fragments that would indicate the use of an explosive device to breach the roof. On the upper parts of the walls, the fragmentation pattern is inconsistent with an explosive event having occurred at the location of the crater. Photographs taken at the scene do not show any fragments that could be attributed to a conventional high-explosive munition.
- 6.146 Furthermore, no remnants of any fusing system have been found or observed on or nearby the cylinder on the rooftop. Additionally, the cylinder does not show any damage which would be consistent with the use of explosives to breach its integrity for the purpose of releasing its content deliberately. These are all indicators that no explosive device was used.

**FIGURE 18: PHOTOS OF THE UPPER PART OF THE ROOFTOP WALLS. THE FRAGMENTATION PATTERN IS NOT CONSISTENT WITH AN EXPLOSIVE EVENT (SOURCE: FFM)**



<sup>160</sup> The Chlorine Institute, “Guidance on Estimating the Area Affected by a Chlorine Release”, Pamphlet 74, 6<sup>th</sup> edition 2015; A.E. Noor & A. Al-Moubaraki, “Corrosion Behavior of Mild Steel in Hydrochloric Acid Solutions”, International Journal of Electrochemical Science, Vol. III, 2008, pp. 806-818.

<sup>161</sup> See “Chemical analyses” section above.

<sup>162</sup> See “Chemical analyses” section above.

- 6.147 The IIT has taken into due account that, from a visual analysis of photographs and videos taken between the day of the incident and 21 April 2018—when the FFM visited Location 2—some items were relocated or removed from the location prior to the arrival of the FFM.<sup>163</sup> By comparing the first available pictures of the scene, taken on 8 April 2018) with photos taken on 11 April 2018, a video published on 20 April 2018 a photo taken on 21 April 2018, it is apparent that several objects at the scene were removed (e.g. the wheel axle) or added (e.g. a red-checked cloth, and a larger, green cloth visible). Furthermore, as noted above, the cylinder was rotated around its axis, parts of the metal cradle were moved and the cradle itself was almost completely removed from the scene prior to the FFM visit.
- 6.148 In line with its methodology, the IIT has analysed the evidence available to it holistically and paid due consideration to the credibility of its sources and to the reliability of the information to which it had access. Consequently, the IIT has assessed the movement of objects at Location 2 to be immaterial to its overall analysis (aimed at identifying the perpetrators of the incident) and subsequent final findings.

---

<sup>163</sup> As highlighted above, the IIT notes that Douma (including both Location 2 and Location 4) was under the control of Jaish al-Islam until 8 April 2018. Further to the ceasefire agreement reached on 8 April 2018 between Jaish al-Islam and the Russian Federation, pro-Government forces took control of the city as of the same date, with the Russian Military Police being in charge of ensuring the security for both locations by the time the FFM had deployed to both sites. See e.g. “Update by the Director-General on the Deployment of the OPCW Fact-Finding Mission to Douma, Syrian Arab Republic, to the Council at Its Fifty-Ninth Meeting”, (EC-M-59/DG.2): “The security for the sites where the FFM plans to deploy was under the control of the Russian Military Police”.



**FIGURE 19: VISIBLE IMPACT CRATER, YELLOW INDUSTRIAL CYLINDER AND THE REMAINS OF THE METAL CRADLE, PARTLY TANGLED IN THE METAL MESH ON THE ROOFTOP.**



Location 4 (“cylinder in the bedroom”)

- 6.149 A yellow industrial cylinder with limited visible damage of the same dimensions and design as the one documented at Location 2, was found on the bed in a room of the apartment building identified in both the FFM Report and in this report as Location 4.

**FIGURE 20: CYLINDER ON THE BED, WITH PARTS OF THE CRADLE CLEARLY VISIBLE (SOURCE: FFM)**

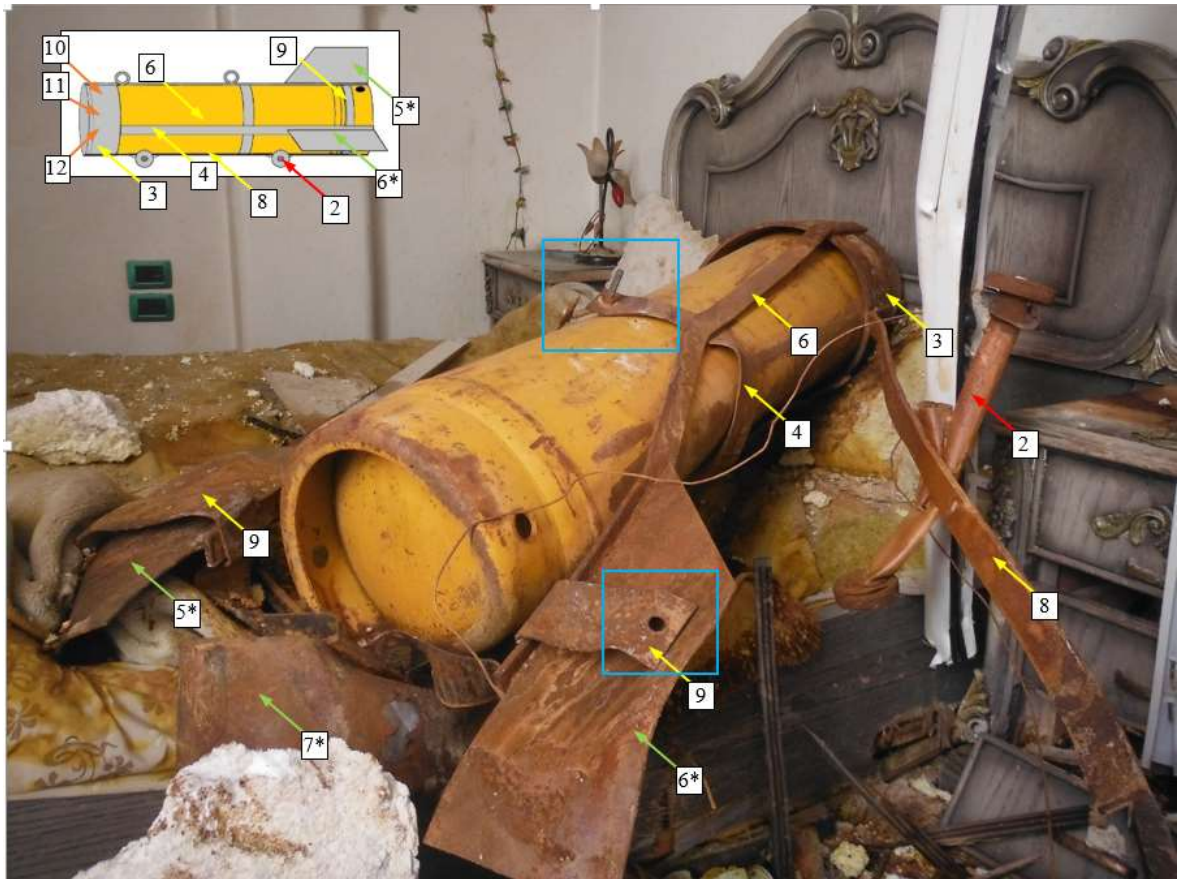

- 6.150 One side of the cylinder is visibly flattened.<sup>164</sup> The overall deformation of the cylinder and cradle (i.e. flattening on one side and bending of the fins) is consistent with the deformation pattern that was calculated through dynamic simulations by external experts consulted by the IIT.
- 6.151 At Location 4, the metal cradle was still attached to the cylinder, although with visible deformations (e.g. an incomplete front-end section and missing front wheel axle). From visual analysis, the munitions specialists consulted by the IIT have determined that the cradle had the same design as the one found at Location 2, as well as at the sites of previous incidents of use of chlorine as a weapon. At Location 4, the valve of the cylinder was still present. As highlighted in the toxicology and chemistry assessments above, this has significant implications for the release of the cylinder's payload.

<sup>164</sup>

See also section: "Assessment of the impact and delivery of the munitions".

**FIGURE 21: THE VALVE (MARKED WITH A YELLOW ARROW) WAS STILL PRESENT AT THE TIME THE CYLINDER WAS FOUND. (SOURCE: FFM)**



6.152 Based on the analysis of authenticated footage from the scene (some of which was taken by the FFM at the location on 25 April 2018),<sup>165</sup> the munitions specialists identified—in proximity to both the cylinder and the cradle—some components that further support that the cylinder was used as a chemical weapon. For instance, an object similar to the circular metal plate that was recovered at Location 2 (sample 16SDS)<sup>166</sup> was visible at the scene.

---

<sup>165</sup> FFM Report on Douma, para. 8.32.

<sup>166</sup> See Figures 6, 8 and 9.



**FIGURE 22: VISIBLE METAL CIRCULAR PLATES IN THE CORNER, MARKED WITH A RED SQUARE AND ENLARGED IMAGE IN THE UPPER RIGHT HAND SIDE CORNER OF THE IMAGE. AN INDUSTRIAL CYLINDER IS VISIBLE ON THE BED (SOURCE: FFM).**



- 6.153 A thinner plate is also visible next to the circular metal plate. From a visual analysis of authenticated videos and pictures taken at the scene, the munitions specialists consulted by the IIT assessed that both items were likely part of the front-end assembly of the cradle, performing the same function as described in relation to the cylinder found at Location 2.<sup>167</sup>
- 6.154 The final position of the cylinder will be further discussed in the next section of this report.<sup>168</sup>
- 6.155 During their site visit to Location 4 on 25 April 2018, the FFM observed visible signs of corrosion on the cylinder, the valve, the harness and other metal objects present in the apartment.<sup>169</sup> The FFM concluded that the corrosion of all metal objects was “a clear indication of their exposure to a corrosive substance”.<sup>170</sup> According to the IIT munitions specialists, this corrosion—which occurred relatively rapidly and was evident when the FFM visited the site on 25 April 2018—supports the conclusion that the cylinder contained a chemical payload.
- 6.156 Commercial gas cylinders such as the one found at Locations 2 and 4 (including those containing liquefied chlorine) are usually made from carbon steel, which is then painted or otherwise coated, often in a colour which identifies its contents by type or class of

---

<sup>167</sup> Cf “Location 2 “cylinder on the roof” above.

<sup>168</sup> See “Assessment of the impact and delivery of the munitions” section.

<sup>169</sup> FFM Report on Douma, para. 8.16.

<sup>170</sup> FFM Report on Douma, para. 8.16.

chemical.<sup>171</sup> When a cylinder impacts a hard surface—such as a concrete roof—the paint almost invariably chips off from the metal. If the cylinder is also damaged, the escaping gas can then react with the exposed metal and corrode it. This would be consistent with the corrosion observed on the cylinder found at Location 4.

- 6.157 As noted above in relation to Location 2,<sup>172</sup> when chlorine gas reacts with the moisture in the air, it becomes highly corrosive to steel and other metals.<sup>173</sup>
- 6.158 Figure 6.22 offers three views of the cylinder found at Location 4, showing the progress of its corrosion over the period that elapsed between the incident and the date of the FFM visit to the site.

**FIGURE 23: A SERIES OF IMAGES OF THE CYLINDER FOUND AT LOCATION 4 SHOWING ITS PROGRESSIVE CORROSION, AS TAKEN ON 9 APRIL 2018 (SOURCE OPCW IIT), 25 APRIL 2018 (SOURCE: FFM), AND 16 NOVEMBER 2020 (SOURCE: OPCW), RESPECTIVELY.**



- 6.159 Figure x(a) (taken on 9 April 2018) shows that the cylinder was not corroded when initially found at the site. The relatively fast degradation indicates that a corrosive chemical substance remained on the site for much of this period (i.e., did not evaporate quickly). An analogous pattern of corrosion can be seen on similar cylinders used in other incidents of use of chemical weapons (notably chlorine), such as the one used in Kafr Zeita (1 October 2016).<sup>174</sup>

---

<sup>171</sup> Hydro Instruments, 2016, 9. See also <https://www.ec21.com/product-details/1000kg-Chlorine-Gas-Cylinder--11024216.html> and supra, footnote xx.

<sup>172</sup> Cf “Location 2 (“cylinder on the roof”) subsection above.

<sup>173</sup> The Chlorine Institute, “Guidance on Estimating the Area Affected by a Chlorine Release”, Pamphlet 74, 6<sup>th</sup> edition 2015; A.E. Noor & A. Al-Moubaraki, “Corrosion Behavior of Mild Steel in Hydrochloric Acid Solutions”, International Journal of Electrochemical Science, Vol. III, 2008, pp. 806-818.

<sup>174</sup> FFM Report on Kafr Zeita, para. 7.45, Figure 7.

**FIGURE 24: PATTERN OF CORROSION ON SIMILAR CYLINDERS USED IN OTHER INCIDENTS OF USE CHEMICAL WEAPONS (NOTABLY CHLORINE) (SOURCE: OPCW, FFM)**



- 6.160 An alternative explanation is that the corrosion may have been caused by the natural humidity in the air. However, in that case the corrosion would have taken place at a substantially slower rate,<sup>175</sup> which is not consistent with the significant extent of corrosion observed about a month after the incident.
- 6.161 These observations indicate that the liquefied gas contained in the cylinder at Location 4 was corrosive and that it was released slowly enough to allow for the corrosion of both the cylinder and other metal objects in the room over an extended period of time (i.e. at least a month). This is consistent with the fact that the cylinder's valve did not shear off, resulting in a slower release of the cylinder's chemical payload. Supporting this assessment is the fact that, when the cylinder at Location 4 was initially found at the scene, six to nine hours after its reported impact, it was still leaking gas.<sup>176</sup>

Distinctive features of the cylinders, pattern of use, and possible scenarios

- 6.162 As also noted in its Second Report in relation to the incident that occurred in Saraqib on 4 February 2018,<sup>177</sup> the IIT considers particularly significant the presence of a metal structure at both Location 2 and Location 4 in Douma, since, as further highlighted in its First Report,<sup>178</sup> munitions with a similar design (that includes a steel "strap-in" structure, also referred to as a "frame" or a "cradle"), began to be observed as means to deliver chlorine payloads as of late 2016.
- 6.163 The cradle generally consists of a front-end assembly, multiple (i.e. two to three) lateral and longitudinal metal straps, stabilising fins, two sets of wheels mounted on two axles and two lifting lugs welded to the longitudinal metal strap on top of the cradle.

---

<sup>175</sup> Ahmad, 2006, 550-575.

<sup>176</sup> FFM Report on Douma, para. 8.69.

<sup>177</sup> Second IIT Report, para. 6.25.

<sup>178</sup> First IIT Report, para. 8.25.

- 6.164 The stabilising fins (which have been observed on different variants of cylinders used for the delivery of chemical weapons in the Syrian Arab Republic since 2013) are installed towards the rear of the cradle. These fins (typically a set of three)<sup>179</sup> are meant to stabilise and orient the munition nose-down, when air delivered.<sup>180</sup> A nose-first impact is particularly beneficial when the munition is intended to be used as a chemical weapon, as it provides a higher chance of the cylinder being damaged and releasing its chemical payload. However, it should be noted that the crude construction and varying deployment practices of these munitions may still result in them impacting base-first or along their length.<sup>181</sup>
- 6.165 As noted in both the First<sup>182</sup> and Second IIT Report,<sup>183</sup> the wheels on the metal cradle facilitate the handling of the cylinder, including while loading and unloading from an aircraft.
- 6.166 The lifting lugs are likely used to help load the munition into an aircraft and/or to deploy it. The lugs observed on the metal cradles attached to cylinders used in previous incidents of use of chemical weapons in the Syrian Arab Republic (as well as at both locations in Douma) are placed in a longitudinal direction (i.e. opposite to what is normally the case on aerial bombs). This is incompatible with the connecting elements which are generally used to mount aerial bombs, and makes it extremely unlikely that the lugs may have been used to attach the cylinder to the outside of fixed-wing or rotary wing aircraft.

---

<sup>179</sup> The three-fin arrangement is an indicator that the cylinder fitting the cradle is intended to be air delivered, since a fourth fin on the “underside” of the munition would scrape the cabin’s floor and thus interfere with the cylinder’s deployment from an aircraft.

<sup>180</sup> See First IIT Report, paras 8.26 and 8.27.

<sup>181</sup> See “Assessment of the impact and delivery of the munitions” below.

<sup>182</sup> First IIT Report, para. 8.27.

<sup>183</sup> Second IIT Report, para. 8.9.



**FIGURE 25: ON THE LEFT: LIFTING LUGS ON THE CRADLE ATTACHED TO THE CYLINDER FOUND AT LOCATION 4 (MARKED WITH A YELLOW SQUARE); ON THE RIGHT: LIFTING LUGS ON AN FAB-250 AERIAL BOMB (MARKED WITH A RED SQUARE). THE DIRECTION OF THE LIFTING LUGS ON THE CRADLE PREVENTS ITS ATTACHMENT ONTO CONVENTIONAL AIRCRAFT WEAPON PYLONS.**

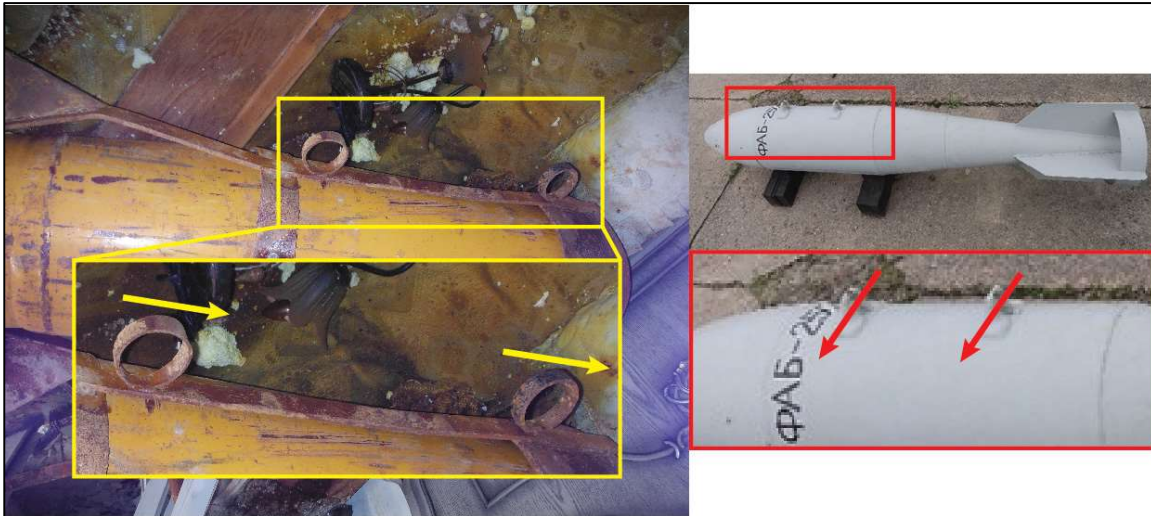

- 6.167 Rather, the lugs appear to be intended to facilitate the handling of the cylinder.
- 6.168 The combined presence of wheels and lifting lugs is an indicator that the cylinder fitted with the cradle is intended to be air delivered, as they contribute significantly to the munitions' manoeuvrability inside and outside the aircraft.
- 6.169 Several subtle variations in design have been observed at different incidents, consistent with efforts to increase the efficiency of this type of weapon. For instance, the number of lateral metal straps observed over time varies from two to three.
- 6.170 However, the IIT notes that the same type of metal cradle found in Douma has been observed in various documented incidents of use of chlorine as a weapon, in which similar improvised munitions were employed as a means of delivery (e.g. Kafr Zeita, 1 October 2016;<sup>184</sup> Ltamenah, 25 March 2017;<sup>185</sup> Saraqib, 4 February 2018).<sup>186</sup>
- 6.171 The IIT also noted that although, in principle, it would be possible to drop these cylinders out of the cargo bay of a fixed-wing aircraft, a consistent pattern has been observed showing similar munitions being dropped from a helicopter, including to deliver a chemical payload (and, notably, chlorine).

<sup>184</sup> See para. 7.66 of Note by the Secretariat S/2020/2022 (dated 31 January 2022) "Report of the OPCW Fact-Finding Mission in Syria Regarding the Incident of the Alleged Use of Chemicals as a Weapon in Kafr Zeita, Syrian Arab Republic, 1 October 2016".

<sup>185</sup> See First IIT Report, paras 8.26 and 8.27.

<sup>186</sup> See Second IIT Report, paras 8.26 and 8.27.



- 6.172 The IIT thoroughly considered the possibility that cylinders of the type identified at both locations in Douma may have been delivered not by helicopter, but rather by surface-to-surface weapons.
- 6.173 The two most common surface-to-surface delivery methods for improvised munitions documented as having been used by parties to the conflict in the Syrian Arab Republic are improvised rocket-assisted munitions (IRAMs) and improvised artillery.
- 6.174 IRAMs use a donor rocket motor to propel and deliver their payload. However, the IIT obtained no evidence of the use of such donor motors at either location. Furthermore, the cylinders found at both Location 2 and Location 4 lack any signs that a rocket motor was attached to them, and are significantly larger than the IRAMs observed by the IIT munitions specialists in the Syrian context.
- 6.175 Improvised artillery has been widely used in the conflict in the Syrian Arab Republic, including large, heavy improvised mortars (so-called “hell cannons”). One of these cannons can be seen in the footage of a military parade held by Jaish al-Islam (which, as noted above, controlled Douma at the time of the incident) in late August 2017.

**FIGURE 26: A “HELL CANNON” (SECOND FROM THE LEFT, WITH BIPOD) AND SEVERAL MORTARS DISPLAYED BY JAISH AL-ISLAM IN EASTERN GHOUTA DURING A MILITARY PARADE IN LATE AUGUST 2017. (SOURCE: [HTTPS://TWITTER.COM/JAISHALISLAM/STATUS/902856591887802368](https://twitter.com/jaishalislam/status/902856591887802368))**



- 6.176 Hell cannons can launch projectiles with masses up to 800 kg. Such a mass is large enough to match the cylinders found at both locations in Douma. However, these cannons require a close fit of the projectile in the barrel, to ensure that the gas released from the explosion of the cannon's charge accelerates the projectile, rather than escapes past it.
- 6.177 As highlighted above, the IIT has noted the evolution in the design of the cradle (incorporating attached fins and axles) associated with the use of chlorine-filled cylinders as a chemical weapon in the Syrian Arab Republic. According to the munitions specialists consulted by the IIT, while finned projectiles can be launched from cannons, this would require the presence of one of the following design features:
- (a) The overall span width of the fins is smaller than the projectile diameter. This is the case with many mortar projectiles, as well as with some of the improvised projectiles used in the conflict in the Syrian Arab Republic. However, that is not the case with the two cylinders found in Douma.
  - (b) The fins are folded inside the projectile prior to firing and extend once the projectile leaves the barrel. The fins of both cylinders found in Douma are fixed, though.
- 6.178 The projectile is surrounded by a so-called "sabot", which closes the gaps between the projectile and the barrel. A cannon large enough to house a projectile with a sabot that completely encompasses it would need a calibre that is at least 5 to 10 times larger than modern mobile field artillery, and much larger than other improvised artillery known to be used in the conflict in the Syrian Arab Republic. A cannon of these dimensions would not be very mobile, and the IIT obtained no evidence of its existence. Furthermore, the IIT munitions specialists assessed it as highly unlikely, if not impossible, that it could be built using improvised means.
- 6.179 Having established that both cylinders found in Douma lacked any of these three features, the IIT determines that the design of both munitions makes it highly unlikely, if not impossible, that they may have been launched using an improvised mortar.
- 6.180 Additionally, no remnants, footage or any other evidence obtained by the IIT in relation to the two cylinders supports the hypothesis of surface-to-surface (rather than air) delivery.<sup>187</sup>
- 6.181 The IIT further assessed the likelihood that the cylinders may have been manually placed at both locations. Besides obtaining no evidence (including from the Syrian Arab Republic or from any other State Party) substantiating this scenario, the IIT also found such a hypothesis to be incompatible with the totality of the information it gathered.<sup>188</sup>
- 6.182 The IIT notes that the damage observed on both cylinders is consistent with an impact following their drop from a considerable altitude. Furthermore, given the cylinders' measurements and the layout of the buildings where they were found, the IIT considers it highly implausible (and obtained no evidence suggesting) that, at two different locations (Location 2 and Location 4), the cylinders may have been carried up the stairs of a multi-storey building, manually placed on the building's upper floor, and scratched,

---

<sup>187</sup> See below "Assessment of the impact and delivery of the munitions".

<sup>188</sup> See below "Assessment of the impact and delivery of the munitions".

damaged, and corroded in a way consistent with the totality of the evidence obtained and analysis performed by the IIT in relation to both sites.

The cylinder found at the warehouse

- 6.183 The FFM “confirmed the presence of a yellow cylinder”<sup>189</sup> at a warehouse they visited in Douma on 27 April 2018 at the request of the Syrian Arab Republic.<sup>190</sup> The latter asserted that “a warehouse containing various chemicals was discovered in the town of Douma after its liberation from the terrorist groups.”<sup>191</sup> The FFM noted that “the cylinder was present in its original state and had not been altered.”<sup>192</sup> The cylinder was reported in a note verbale by the Syrian Arab Republic as being a chlorine cylinder.<sup>193</sup> However, for safety reasons, the FFM did not deem it “feasible to verify or sample the contents” of the cylinder during its visit.<sup>194</sup>
- 6.184 The FFM highlighted that “there were differences in this cylinder compared to those at Locations 2 and 4”.<sup>195</sup> From a visual analysis, the munitions specialists consulted by the IIT notes that the yellow cylinder (visible in Figure A.8.2 of the FFM report) had no attached cradle, and a valve protection cap was mounted on it. Lacking any samples from the cylinder and not having had direct access to the alleged warehouse, the IIT is not in the position to determine what substances (if any) the cylinder contained. Therefore, based on the information available to it, the IIT was not in the position to make any determination as to the connection of the observed cylinder with the incident.

---

189 FFM Report on Douma, Annex 8, para. 7.

190 Permanent Mission of the Syrian Arab Republic, Note Verbale no. 43, 20 April 2018; See also “Chemical analyses” section above.

191 Ibid.

192 FFM Report on Douma, Annex 8, para. 7.

193 Permanent Mission of the Syrian Arab Republic, Note Verbale no. 43, 20 April 2018.

194 FFM Report on Douma, Annex 8, para. 7.

195 FFM Report on Douma, Annex 8, para. 7.

**FIGURE 27: IN THE LARGER IMAGE: YELLOW INDUSTRIAL CYLINDER FOUND AT THE WAREHOUSE LOCATION. NO CRADLE IS ATTACHED TO THE CYLINDER AND THE VALVE PROTECTION CAP (MARKED BY A YELLOW SQUARE) IS MOUNTED. THE TOP PART OF THE SAME CYLINDER IS SHOWN ON THE SMALLER IMAGE (MARKED IN WHITE). IN THE BOTTOM IMAGES, CYLINDERS WITH THE SAME FEATURES USED IN THE INCIDENTS IN KAFR ZEITA (1 OCTOBER 2016) (MARKED IN GREEN) AND LTAMENAH (25 MARCH 2017) (MARKED IN BLUE).**



### Conclusions

- 6.185 The IIT has reasonable grounds to believe that the cylinders observed at both Location 2 and Location 4 were intended to be used as air-delivered munitions.
- 6.186 Design features of both cylinders, such as a heavy-nose section (the use of which is to increase the likelihood of a frontal nose-first impact of similar cylinders to facilitate the release of their content) has been well documented throughout the conflict in the Syrian Arab Republic, as well as of the metal cradles fitted to them<sup>196</sup> (e.g. the additional fins) indicate that they were intended to be delivered via aircraft. These design features bear a close resemblance to those displayed by the munitions used in chemical weapon incidents carried out in the same period of the conflict (e.g. Ltamenah, 25 March 2017;<sup>197</sup> and Saraqib, 4 February 2018<sup>198</sup>), and attributed by the IIT to the Syrian Arab Republic.
- 6.187 Furthermore, the orientation of the lifting lugs on the metal cradles found at both locations indicates that the cylinders were not designed to be attached to the outside weapons pylon of an aircraft, but rather to be pushed out of the cargo bay of either a helicopter or fixed-wing aircraft. The presence at both locations of wheels mounted onto axles, which are intended to facilitate the handling of the cylinders, further supports this conclusion.
- 6.188 Mi-8/17 helicopters are particularly suitable for the purpose of delivering medium and large conventional and chemical improvised munitions, due to their large cargo bay, which can store multiple medium-to-large barrels. This is consistent with the findings reached by the IIT in both its First and its Second Report, in which it concluded that chlorine-filled cylinders similar to the ones found in Douma were dropped by Mi-8/17 helicopters operated by the Syrian Arab Republic in Ltamenah and Saraqib.
- 6.189 At Location 2, the damage observed on the cylinder was consistent with what would have been expected from the drop from an aircraft, rather than from e.g. an adjacent building. Traces of dried condensation droplets, observed on the cylinder's body, are consistent with condensation resulting from auto-refrigeration, which, as noted above, is a phenomenon characteristic of liquefied compressed gasses, such as chlorine, being rapidly released. This is also consistent with the fact that the valve of the cylinder at Location 2 broke off, resulting in the rapid release of gas. The significant corrosion observed on the metal cradle further supports the hypothesis of chlorine release from the cylinder. This is consistent with the conclusions reached by the IIT chemistry expert.

---

<sup>196</sup> See assessment for Location 2 above. In light of the information obtained, considered in its totality, the IIT has reasonable grounds to believe that the cradle found next to the cylinder at Location 2 was fitted to the cylinder and detached upon impact. Nonetheless, the IIT assesses that the presence of the cradle, as well as its design, is not decisive in determining whether the munition was air-delivered. Instead, it is the significant body of evidence obtained by the IIT that strongly suggests that the cylinder was dropped from an aircraft.

<sup>197</sup> See First IIT Report, Annex 4.

<sup>198</sup> See Second IIT Report, paras 6.19-6.23.



- 6.190 At Location 4, the overall damage to the cylinder indicates that it was air delivered and impacted horizontally. Visible signs of corrosion on the cylinder—whose valve was not sheared off—are consistent with the slow release of chlorine, as well as with analogous patterns of corrosion observed on similar cylinders used in other incidents of use of chlorine as a chemical weapon (e.g. Kafr Zeita, 1 October 2016). This assessment is also consistent with the chemistry findings reached by the IIT.
- 6.191 No indication was found at either location that explosives had been used to ensure the release of the cylinders' content.
- 6.192 The possibility that the cylinders may have been delivered by surface-to-surface weapons, i.e. IRAMs or improvised artillery, was also ruled out. Both cylinders were significantly larger than the IRAMs documented in the Syrian context, and lacked any signs that a rocket motor was attached to them. Furthermore, the design of both munitions makes it highly unlikely, if not impossible, that they had been launched using improvised mortars. Finally, no remnants, footage, or any other evidence obtained by the IIT supports the hypothesis of surface-to-surface (rather than air) delivery.
- 6.193 The IIT further considered the manual placement of cylinders at both locations to be inconsistent with the damage observed on both cylinders, as well as with the totality and consistency of the evidence obtained and analyses performed in relation to both sites. This scenario will be further assessed in the next section.
- 6.194 In light of the above, the IIT has reasonable grounds to believe that the cylinders found at Location 2 and Location 4 were dropped from a considerable height by a rotary-wing aircraft.
- 6.195 The IIT also has reasonable grounds to believe that the cylinders found at both locations contained a corrosive chemical payload and were the source of the chlorine gas identified at both Locations 2 and Location 4 (see the conclusions of the “Chemical Analyses” section above).

#### **Assessment of the impact and delivery of the munitions**

- 6.196 The IIT consulted two experts—a terminal ballistics expert and a missile trajectory expert—neither of whom had worked on the incident before, for the purpose of assessing the different hypotheses as to how the cylinders may have been delivered to, or placed at, Location 2 and Location 4, respectively.
- 6.197 Such an assessment was critical in order to corroborate or discard the main hypotheses the IIT's investigation focused on,<sup>199</sup> i.e. that of the “staging” of a chemical attack at two locations in Douma on 7 April 2018, and that of an attack with chlorine released through two cylinders dropped from the air at the said locations and on the said date.

---

199

See “Scenarios” section above.

- 6.198 In particular, the experts were tasked with assessing whether the observed damage<sup>200</sup> at both locations would match the damage one could expect from the cylinders' impact, and—if so—with what attitude<sup>201</sup> and impact velocity. In parallel, the experts were asked to consider other plausible methods of delivery, potentially constitutive of the “staging” scenario, e.g. whether the cylinders may have been dropped from adjacent buildings, or placed manually at both locations.
- 6.199 To this end, the IIT thoroughly considered elements related to the craters identified at each location, building upon the analysis conducted by several experts and specialists (including three experts consulted by the FFM<sup>202</sup> in the framework of its own investigation, whose expertise ranged from engineering to munitions, ballistics and material construction and properties). The IIT further took into consideration empirical and analytical models, including modelling the impact of the two gas cylinders at the respective locations; relevant scientific literature; satellite imagery, 3D models, pictures and video recordings obtained in the aftermath of the incident; open-source materials; positions expressed by certain States Parties;<sup>203</sup> and an “Engineering Assessment” drafted by a then-OPCW staff member and shared by the latter with the IIT.
- 6.200 Experiments were also performed using similar cylinders to those found at Locations 2 and 4. The main purpose of these experiments was to assess the possibility that the cylinders may have been thrown from adjacent buildings.

Preliminary observation of the scenes

*Location 2 (“cylinder on the roof”)*

- 6.201 The cylinder at Location 2 was found on the concrete floor of a rooftop balcony, with its front end located in a crater in the floor.

---

200 The descriptions of the damage at both locations are based on pictures taken by the FFM, the FFM Report on Douma, as well as on the expert assessment produced by two munitions experts for the purposes of the present report, see the FFM Report on Douma, Annex 12.

201 A projectile's “attitude” (or “pitch angle”) is defined as the angle between the projectile's length axis and the local horizontal; see “Assessment of impact phenomena at Locations 2 and 4” subsection below.

202 See FFM Report on Douma, pages 17 (item 8.30) and 19 (item 8.34) and Annex 12, page 104. It should be noted that, while the findings of the three expert reports commissioned by the FFM have been reviewed and summarised by the IIT for the purposes of the present report, those are not in the public domain.

203 Permanent Representation of the Russian Federation to the Secretariat of the Organisation for the Prohibition of Chemical Weapons, Note Verbale No. 759, 2019.

**FIGURE 28: CYLINDER ON THE ROOFTOP FLOOR AT LOCATION 2**



6.202 The rooftop overlooks Douma towards the north, which is on the left in the image above, with the window (on the right) situated in the southern wall. The rooftop floor is covered in rubble, as well as metal fragments and mangled parts of a metal mesh.<sup>204</sup>

**FIGURE 29: THE CYLINDER ON THE BALCONY AT LOCATION 2, SHOWING A GRID PATTERN CORRESPONDING TO THE METAL MESH**



6.203 The figure below shows another view of the cylinder, taken from the door opening to the rooftop. As noted above, the paint on the side of the cylinder shows a grid pattern corresponding to the metal mesh. The missile trajectory expert consulted by the IIT concurred with the IIT munitions experts (from whom they worked independently) that this may be the result of the cylinder impacting the mesh with a relatively low tangential velocity.<sup>205</sup> The FFM Report also shows images<sup>206</sup> of the corner of the wall above the impact location, with clearly visible damage, which may have been caused by the cylinder impacting the wall before landing on the rooftop floor.

---

204 Cf. “Assessment of remnants” above.

205 See “Assessment of remnants”.

206 FFM Report on Douma, page 55, Figure A.6.4.



*Location 4 (“cylinder in the bedroom”)*

6.204 At Location 4, a cylinder was found on top of a bed on the upper floor of an apartment building.

**FIGURE 30: CYLINDER ON THE BED AT LOCATION 4.**

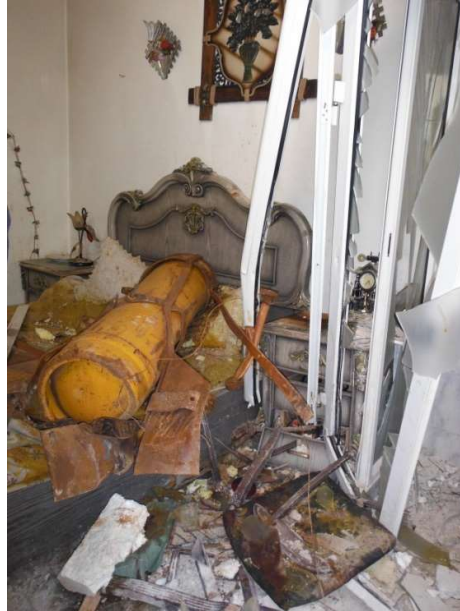

6.205 The figure above shows an elongated hole in the roof above the bedroom at Location 4.

**FIGURE 31: CRATER IN THE ROOF AT LOCATION 4, AS SEEN FROM ABOVE.**



6.206 The FFM<sup>207</sup> measured the crater as approximately 166 cm long and 105 cm wide. Notably, the red-coloured water tank to the right of the hole appears to be undamaged. If the hole was the result of the cylinder’s impact, the absence of visible damage on the

---

<sup>207</sup> FFM Report on Douma, Annex 7, pp. 60 and 62.

water tank would provide a preliminary indication that the cylinder impacted flying slowly from east to west (i.e. with a low horizontal velocity) at the scene.

**FIGURE 32: HOLE IN THE ROOF AT LOCATION 4, AS SEEN FROM BELOW**



**FIGURE 33: HOLE IN THE ROOF AT LOCATION 4, SEEN FROM ABOVE AND BELOW**

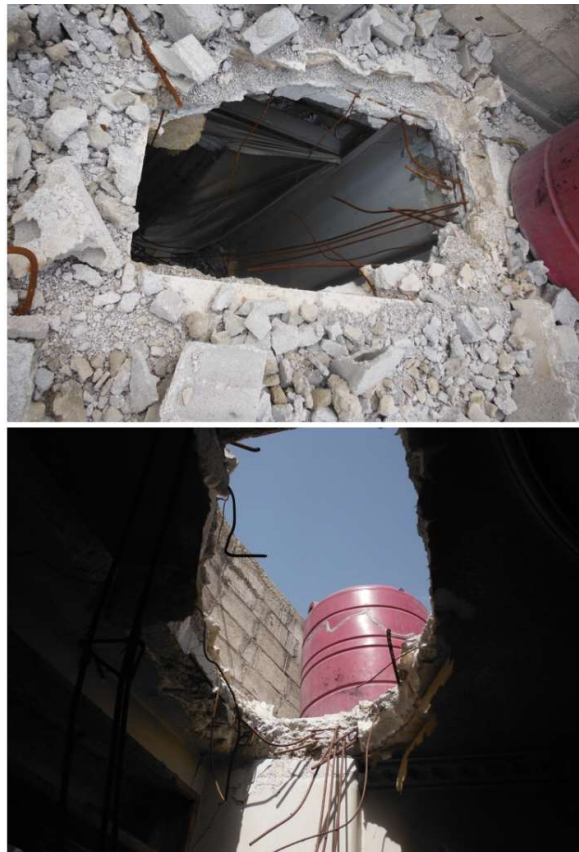

6.207 The wall directly under the red water tank has sustained damage, as can be seen both in both figures above. The plaster is damaged just below the ceiling and a crack in the wall can be seen in the corner of the room. This points to the crater being the result of an impact phenomenon with a considerable vertical velocity.

6.208 The hole is not located above the bed where the cylinder was found. Instead, it is near the south-western corner of the room, diagonally opposite the corner on the left of the bed's headboard.

**FIGURE 34: POSITION OF THE CRATER AT LOCATION 4 IN RELATION TO THE BED'S HEADBOARD**



Assessment of impact phenomena at Locations 2 and 4

- 6.209 To study the impact phenomena at Location 2 and Location 4, the terminal ballistics and missile trajectory experts consulted by the IIT considered the relevant data collected in relation to both locations, such as the dimensions of the craters.
- 6.210 The description of the damage at both locations is based on pictures taken by the FFM, the FFM Report on Douma,<sup>208</sup> and video and photographic footage obtained from both FFM and IIT witnesses, as well as on the assessment produced by two munitions specialists for the purposes of the present report.
- 6.211 As noted above, experiments were also commissioned from specialised external institutions, including to assess the possibility that the cylinders may have been thrown from adjacent buildings (the height of which was also independently determined by the IIT via 3D reconstruction from satellite images).

<sup>208</sup> See FFM Report on Douma, Annex 12.

**FIGURE 35: 3D VISUALISATION OF HEIGHTS AND DISTANCES OF ADJACENT BUILDINGS TO LOCATIONS 2 AND 4**

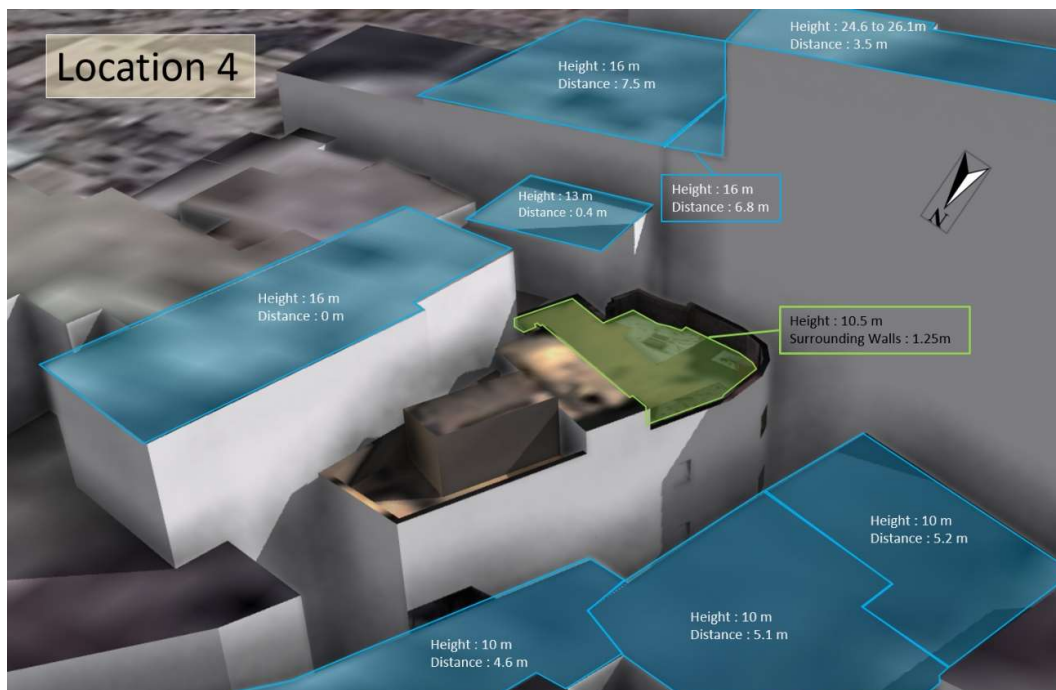
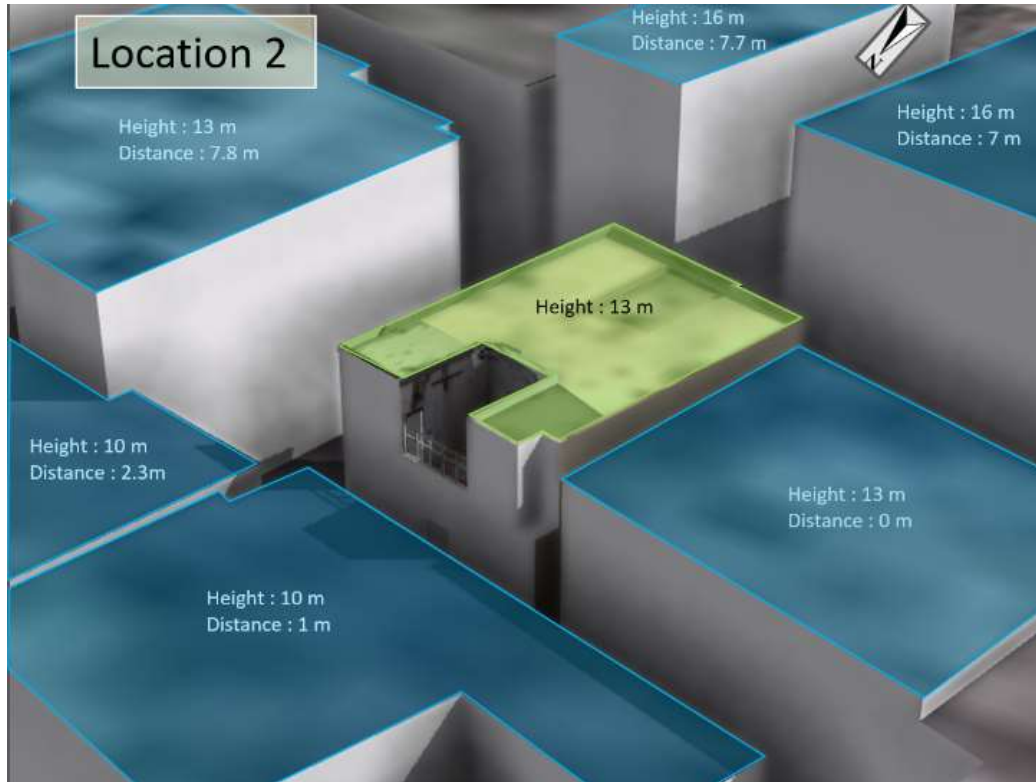



- 6.212 A first set of experiments was conducted to assess the deformation caused to a replica cylinder and cradle when dropped from a height of 16 m (i.e. the estimated height difference between the crater at Location 4 and the highest adjacent building) and impacting a replicated concrete roof structure. A second set was conducted to examine the damage caused to the roof structure itself by the impact of the cylinder and cradle dropped from 16 m. These replicates were built based on information and photographs provided by the OPCW.
- 6.213 Finite Element<sup>209</sup> simulations were also performed to further understand the observed impact phenomena at both locations.
- 6.214 The holistic assessment of the results of the analyses and experiments performed provides a coherent picture of the impact aspects at both Location 2 and Location 4.

*Location 2 (“cylinder on the roof”)*

- 6.215 At Location 2, the dimensions of the crater near the cylinder on the rooftop were 66 cm x 50 cm. Its shape was roughly elliptical. The three independent expert reports commissioned by the FFM all concur that the crater was caused by the impact of that cylinder.
- 6.216 The visible deformation of the steel rebars in the concrete towards the interior of the building indicate that the hole in the roof was created by a force coming from the outside to the inside.

**FIGURE 36: FIGURE X: DEFORMATION OF THE STEEL REBARS IN THE CONCRETE TOWARDS THE INTERIOR OF THE BUILDING. (SOURCE: FFM)**



---

<sup>209</sup> Finite Element is a common method used to numerically solve differential equations arising in engineering and mathematical modelling.

**FIGURE 37: VISIBLE DEFORMATION OF THE STEEL REBARS IN THE CONCRETE TOWARDS THE INTERIOR OF THE BUILDING AT LOCATION 2.**



6.217 The terminal ballistics expert consulted by the IIT assessed that, for the cylinder to perforate the reinforced concrete on the rooftop at Location 2, an impact velocity of about 30 m/s was sufficient for vertical impact, i.e. perpendicular to the concrete. The Finite Element simulations are consistent with experiments presented in scientific literature. The terminal ballistics expert further assessed that, in order to simulate a crater similar to the one observed at Location 2, a vertical impact velocity of 55 m/s and a pitch angle<sup>210</sup> of -45° were required.

6.218 The terminal ballistics expert further determined that the damage observed at Location 1 was not consistent with the use of an explosive charge.

*Location 4 (“cylinder in the bedroom”)*

6.219 At Location 4, the dimensions of the crater in the bedroom were 166 cm x 105 cm.<sup>211</sup> According to FFM measurements, the height of the bedroom ceiling was approximately 3 m.

6.220 For Location 4, the terminal ballistics expert assessed that the cylinder landed<sup>212</sup> in a nearly horizontal attitude. This assessment is based on the elongated shape of the crater, as well as on the flattening of the cylinder (as also observed by the IIT munitions

<sup>210</sup> The pitch angle is the angle between the projectile length axis and horizontal.

<sup>211</sup> See FFM Report on Douma, pp. 60 and 62.

<sup>212</sup> That is, if the crater was the result of an impact. Alternative hypotheses as to how the cylinder may have reached Location 4 will be addressed further below in this section.

specialists).<sup>213</sup> Numerical simulations of the impact show that a cylinder landing in a nearly horizontal attitude would require an impact velocity of no less than 50 to 60 m/s to fully perforate the roof.<sup>214</sup> Simulations were also performed for a higher strength of the reinforced concrete. Based on these simulations, in this case, the minimum velocity required to cause cylinder breakthrough of the concrete roof would have been 72 m/s.<sup>215</sup>

- 6.221 Also in relation to Location 4, the experts consulted by the IIT considered a scenario (also discussed in detail by one of the experts consulted by the FFM) in which the cylinder bounced from the floor of the bedroom and arrived at the position at which it was found on the bed without human intervention. The experts deemed this scenario to be possible. The explanation will be discussed in further detail below in this section.
- 6.222 As for the hypothesis that the cylinder at Location 4 may have been dropped from an adjacent building (with a drop height of 16 m, according to 3D building reconstruction from satellite images), impact experiments indicated that dropping the cylinder from such a height, where the latter impacts horizontally, would not result in the penetration of the reinforced concrete. These impact experiments confirm Finite Element modelling results.
- 6.223 The combined results of experiments and Finite Element simulations allowed the IIT to confidently rule out any scenarios with a drop height of 16 m or less, at which the cylinder could not have reached the minimum velocity (i.e. 50 m/s) required to fully perforate the roof.
- 6.224 Also for Location 4, the terminal ballistics expert concluded that the damage observed was not consistent with the one that would have resulted from the use of one or more explosives.

#### Analysis of cylinders' behaviour

- 6.225 Once the terminal ballistics expert determined the cylinders' attitudes<sup>216</sup> and impact velocities—based on, and consistent with, the damage observed at both locations—the missile trajectory expert assessed different hypotheses as to how the cylinders may have been delivered to, or placed at, Location 2 and Location 4 respectively. These include the possibility that the cylinders may have been placed manually at both locations; a scenario in which they would have been launched via surface-to-surface artillery; and the hypothesis whereby the cylinders would have been delivered by an aircraft or dropped from an adjacent building. In order to gain a more detailed understanding of the cylinders' behaviour at both locations, the expert reviewed the totality of the available data pertaining to the cylinders' trajectories, determining the relevant parameters and relying on bespoke computer modelling.
- 6.226 Performed simulations of trajectories included, for each cylinder (including their cradle),<sup>217</sup> the two-dimensional motion and its pitch dynamics, i.e. how the attitude

---

<sup>213</sup> See "Assessment of remnants" section above.

<sup>214</sup> An assessment of the corresponding height will be provided in subsection "Trajectory results" below.

<sup>215</sup> An assessment of the corresponding height will be provided in subsection "Trajectory results" below.

<sup>216</sup> See definition as provided above in section "Assessment of the impact and delivery of the munitions".

<sup>217</sup> The simulations performed by the missile trajectory expert consulted by the IIT assume, based on the totality of the information obtained by and available to the IIT, that a cradle was attached to both cylinders prior to their impacting the buildings.

changes in time during the flight. Impact velocities and the attitude of each cylinder on impact were calculated, for different drop heights, initial velocities, different initial pitch angles and pitch rates.<sup>218</sup>

Relevant properties of the cylinders

6.227 The flight dynamics of the cylinders depend on properties such as their shape and mass. The relevant properties of the cylinders are based on pictures and measurements of the cylinders taken by the FFM, when inspecting the cylinders in situ, as well as on the relevant assessments undertaken by the munitions experts consulted by the IIT.

**FIGURE 38: CYLINDER RECOVERED AT LOCATION 4, PHOTOGRAPHED BY AN OPCW TEAM IN NOVEMBER 2020**



6.228 The properties of the cylinders at both locations in the IIT missile trajectory expert's model are based on the FFM's measurements and are outlined in the table below:

Parameter	Symbol	Value
Mass <sup>219</sup>	$m$	297.4 kg
Diameter	$d$	0.35 m
Location of centre of mass	$x_{cm}$	0.775 m
Moment of inertia	$I$	50.1 kgm <sup>2</sup>

<sup>218</sup> The pitch rate is the rate of change of the pitch angle, which describes how the cylinder rotates.

<sup>219</sup> In the missile trajectory expert's calculations, the tank was considered to be full; see further below in this subsection.



6.229 The numbers in the table are based on a reconstruction of the assembly<sup>220</sup> with measurements as illustrated below:

**FIGURE 39: RECONSTRUCTION, WITH MEASUREMENTS, OF THE CYLINDER'S ASSEMBLIES FOUND IN DOUMA, AS USED IN THE SIMULATIONS PERFORMED BY THE MISSILE TRAJECTORY EXPERT CONSULTED BY THE IIT**

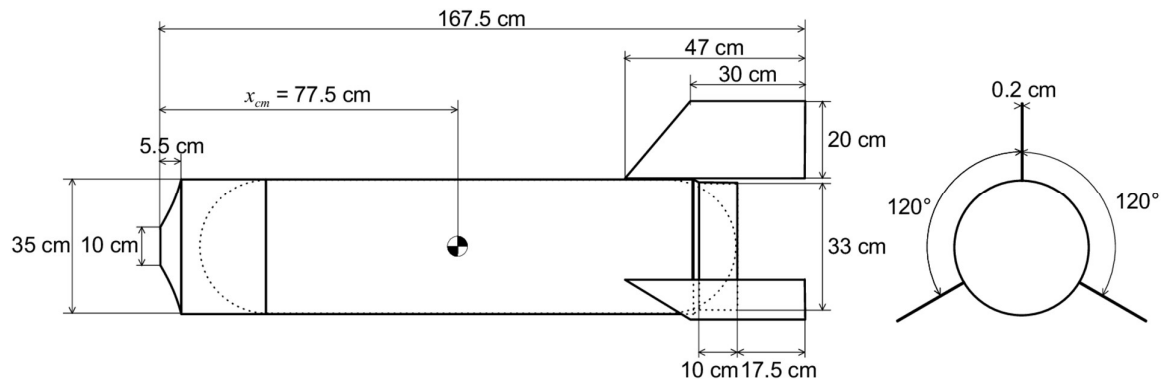

6.230 However, the model acknowledges—and accounts for the fact that—some elements of uncertainty remain, and that, at both locations, it is impossible to determine the exact configuration of the assembly prior to impact.

6.231 For instance, at Location 2, the cradle appears to have detached upon impact and was found mangled next to the cylinder.

6.232 As noted above, at Location 4 the cylinder seems to have shifted forward relative to its support cradle. Due to the damage, the length of the pipe through the front plate and of the metal strips that connect the nose cap to the tail fins (and thus the exact overall length of the assembly) is unknown.

6.233 Furthermore, it is unclear whether the cylinders were completely full or whether some of the internal volume was left empty. As mentioned above, the missile trajectory expert's calculations were performed on the basis of the tank being full. However, the effects of the tank being partially empty have been factored in the modelling and will be discussed further below in this section.

#### Review of FFM expert reports assessments

6.234 As noted above, to evaluate whether the damage at Locations 2 and 4 is consistent with the impact of the cylinders found at each location, the terminal ballistics expert and the missile trajectory expert consulted by the IIT reviewed and considered all available materials when making their assessment. Reports considered by the IIT included estimates of the heights, and simulations of the trajectories necessary to achieve the impact velocities required for the observed damage.

220

For the purposes of this report, the term “assembly” refers to a cylinder fitted with a steel strap-in structure, i.e. a steel frame with a weighted nose part, wheels, three tail fins, and two lifting loops; see First IIT Report, para. 8.26 and Second IIT Report, para. 6.25.; Cf. also FFM Report, Annex 7, page 61, Figure 8.7.5.

6.235 The findings from these reports pertaining to the cylinders' trajectories can be summarised as follows.

*Location 2 ("cylinder on the roof")*

6.236 All the expert reports available to the IIT confirm that the cylinder at Location 2 was dropped from above. There is, however, no consensus on the drop height, due to different interpretations of what happened to the cylinder before it hit the rooftop floor (i.e. direct impact on the rooftop versus cylinder impacting the wall above the rooftop and subsequently impacting the latter).<sup>221</sup>

6.237 In the event that the cylinder hit the rooftop floor directly, the relevant parameters are provided in one of the expert reports commissioned by the FFM. The report determined that the cylinder impacted at a velocity close to 55 m/s and a pitch angle of  $-45^\circ$  (i.e. "nose-down" or "nose-first").

**FIGURE 40: THE PITCH ANGLE IS THE ANGLE BETWEEN THE PROJECTILE LENGTH AXIS AND HORIZONTAL; THE ANGLE OF ATTACK IS THE ANGLE BETWEEN THE PROJECTILE LENGTH AXIS AND THE TRAJECTORY**

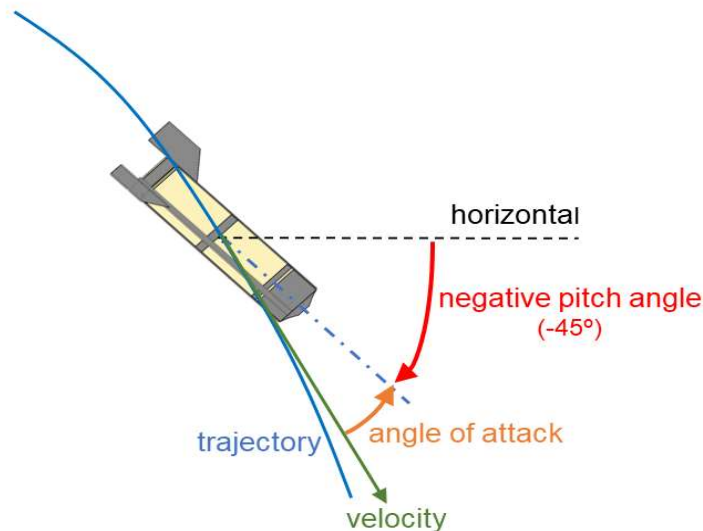

<sup>221</sup>

A different hypothesis (i.e. that the cylinder was not air dropped) will be addressed below in the "Assessment of alternative delivery methods" subsection.

*Location 4 (“cylinder in the bedroom”)*

- 6.238 For Location 4, there is agreement among the experts around a vertical impact velocity of 50 to 60 m/s, a pitch angle at impact close to 0° (meaning that the cylinder would have hit the roof more or less broadside, in a horizontal or nearly horizontal attitude) and a minimum drop height between 100 and 166 m.
- 6.239 There was no hole on the bedroom floor. That means that the cylinder penetrated the building roof at a velocity that would have not been sufficient for it to damage the floor. One of the expert reports commissioned by the FFM shows that for the cylinder to have penetrated the roof and also damaged the floor of the bedroom underneath, an impact velocity of 125 m/s or higher would have been required. Therefore, this is the maximum impact velocity that the IIT missile trajectory expert considered in his assessment. The cylinder’s attitude at impact at Location 4 further suggests it was dropped with a high pitch angle and angle of attack.<sup>222</sup>

Implications for trajectories

- 6.240 The behaviour of a projectile in flight depends on whether it is stable or unstable. If it is stable, the aerodynamic forces acting on the cylinder will push the angle of attack towards zero. If the projectile is unstable it will tumble in a manner that is very hard to predict.
- 6.241 Whether the cylinders used in Douma were stable would have depended on their shape and on their centre of mass.
- 6.242 Based on the mass distribution and on the shape of the overall assembly of both cylinders, the IIT missile trajectory expert’s assessment is that both munitions were indeed stable.<sup>223</sup>

---

<sup>222</sup> Claims that the hole was too small to match the cylinder will be addressed in more detail below in subsection “Assessment of alternative delivery methods”.

<sup>223</sup> As noted in the previous section, the overall configuration of both cylinders’ assembly (including their tailfins and the heavy plates) increased the latter’s stability.

**FIGURE 41: TRAJECTORY OF AN AERODYNAMICALLY STABLE PROJECTILE DROPPED AT NON-ZERO HORIZONTAL VELOCITY WITH A HIGH INITIAL ANGLE OF ATTACK**

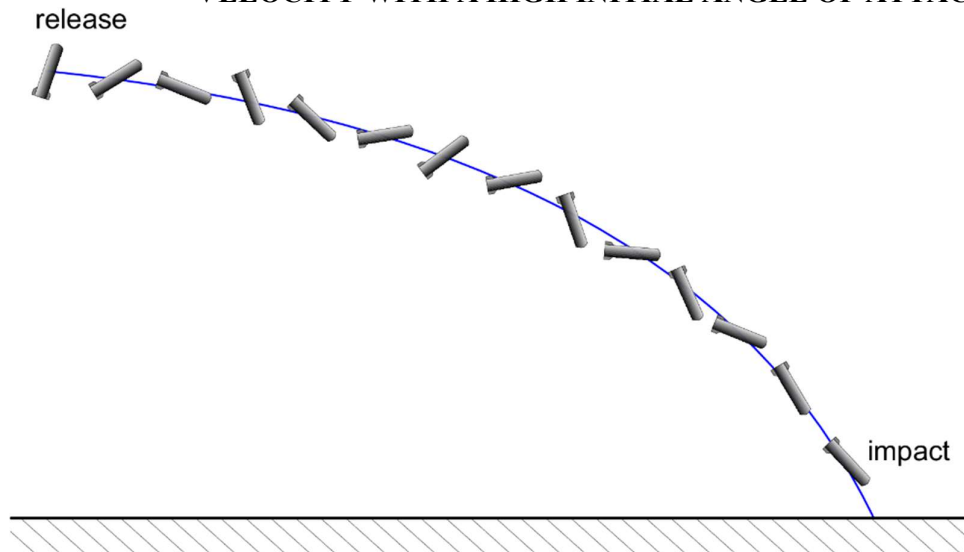

- 6.243 If a projectile is stable and launched at a positive angle of attack, the angle of attack decreases. However, due to inertia, it decreases to zero gradually and it may even overshoot, becoming negative, before swinging back again. This process may repeat multiple times, with the pitch angle and the angle of attack oscillating in time, with decreasing amplitude (as illustrated above).
- 6.244 Crucially, if a projectile is aerodynamically stable and there is a large height difference between the location where it is dropped and the one at which it impacts, the pitch oscillations would have damped out by the time the projectile would strike the target. Therefore, the cylinder—stabilised at impact—would hit nose-down. If the projectile is released with a small angle of attack, even from a lower height, the pitch oscillations will be small from the start and, again, the projectile will strike the target nose-down.
- 6.245 As noted above, at Location 2, the cylinder hit the rooftop nose-down. If the cylinder impacted the rooftop floor directly, trajectory simulations should be able to recreate this nose-down attitude. However, the possible impact of the cylinder on the rooftop wall prior to hitting the floor would have altered its trajectory. This would preclude any conclusive determination as to pitch angle and angle of attack at which the cylinder would have been dropped.
- 6.246 At Location 4, the damage observed on the building roof matches a projectile with a pitch angle close to  $0^\circ$ . This indicates that the cylinder was dropped with a high initial pitch angle and angle of attack and from an altitude sufficiently low for the pitch angle to still be oscillating at impact (and thus resulting in the cylinder landing in a nearly horizontal attitude). In light of the above, the simulations performed by the missile trajectory expert consulted by the IIT sought to identify combinations of initial velocities and drop heights for which the impact velocity matched the damage observed at Location 4 and for which the cylinder indeed impacted in a nearly horizontal attitude.

### Description of the simulation model

- 6.247 The analyses performed by the IIT missile trajectory expert to determine plausible methods of delivery of the cylinders at both Location 2 and Location 4 relied on simulations of projectile trajectories. These include the two-dimensional projectile motion and its pitch dynamics, i.e. how the cylinder's attitude changes in time during the flight. For this, aerodynamic coefficients of both cylinders were derived, with each cylinder's shape and properties based on measurements and photographs. Impact velocities and the attitude of each cylinder at impact were calculated for different drop heights and velocities of the delivery vehicle, and with the latter flying horizontally.<sup>224</sup>
- 6.248 Both the initial pitch angle and angle of attack have been varied in the simulations to account for a wide range of variables and scenarios.
- 6.249 At Location 2, the simulation model is only applicable if the cylinder impacted the rooftop floor directly.
- 6.250 At Location 4, the horizontal attitude of the cylinder at impact requires it to have been dropped with a high angle of attack.
- 6.251 The fact that the simulation model includes an atmospheric model<sup>225</sup> means that its results depend on the altitude relative to sea level. The approximate elevation of the terrain in Douma is 743 m above sea level. The drop height used in the model accounts for the average elevation of the terrain in Douma and the height of both buildings.<sup>226</sup>
- 6.252 Finally, the model did not take wind into account. The wind velocity in Douma on 7 April 2018 was approximately 2 – 3 m/s.<sup>227</sup> It is assessed that this would not have significantly affected the relevant dynamics of the cylinders' fall, and thus is not relevant for the conclusions.

### Trajectory results

- 6.253 The missile trajectory expert consulted by the IIT simulated almost 80,000 trajectories. In order to determine possible drop heights, simulations were performed in which the vertical impact velocity of the cylinders was calculated as a function of their drop heights and initial horizontal velocities.
- 6.254 As mentioned above, the damage at Location 4 shows that the cylinder landed in a nearly horizontal attitude, indicating that it was dropped with a high initial pitch angle and angle of attack. Therefore, an initial pitch angle of 90° was chosen in the simulations.

---

<sup>224</sup> The exact way in which the cylinders are dropped accounts for small differences between the initial velocity of the cylinder and the velocity of the delivery vehicle. In the simulation, these velocities are identical.

<sup>225</sup> Known as "International Standard Atmosphere" (ISA).

<sup>226</sup> While the precise altitude would not impact significantly on the results, what matters is that the drop altitude used in the model is significantly higher than sea level to ensure reasonable values for the atmospheric density.

<sup>227</sup> See "Meteorological conditions" section above.

6.255 An initial pitch rate of 0°/s was chosen in the first simulations, and in subsequent simulations higher values were also investigated. Initial velocities between 1 and 70 m/s are shown below, which are consistent with the relatively low horizontal velocity at impact indicated by the damage at both Location 2 and Location 4. The range of drop heights in the simulations was chosen so that the impact velocities would include a range between 50 and 60 m/s, i.e. the range of velocities associated with the damage at both locations.<sup>228</sup>

6.256 In the figure below, the colours indicate the impact velocity.

**FIGURE 42: VERTICAL IMPACT VELOCITY AS A FUNCTION OF THE INITIAL VELOCITY AND DROP HEIGHT FOR AN INITIAL PITCH ANGLE OF 90° AND A 0°/S PITCH RATE, FOR HEIGHTS BETWEEN 100 AND 240 M. FOR EXAMPLE, THE WHITE MARKER CORRESPONDS TO A DROP HEIGHT OF 175 M AND AN INITIAL VELOCITY OF 15 M/S. THE RED MARKER CORRESPONDS TO A DROP HEIGHT OF 175 M AND AN INITIAL VELOCITY OF 40 M/S**

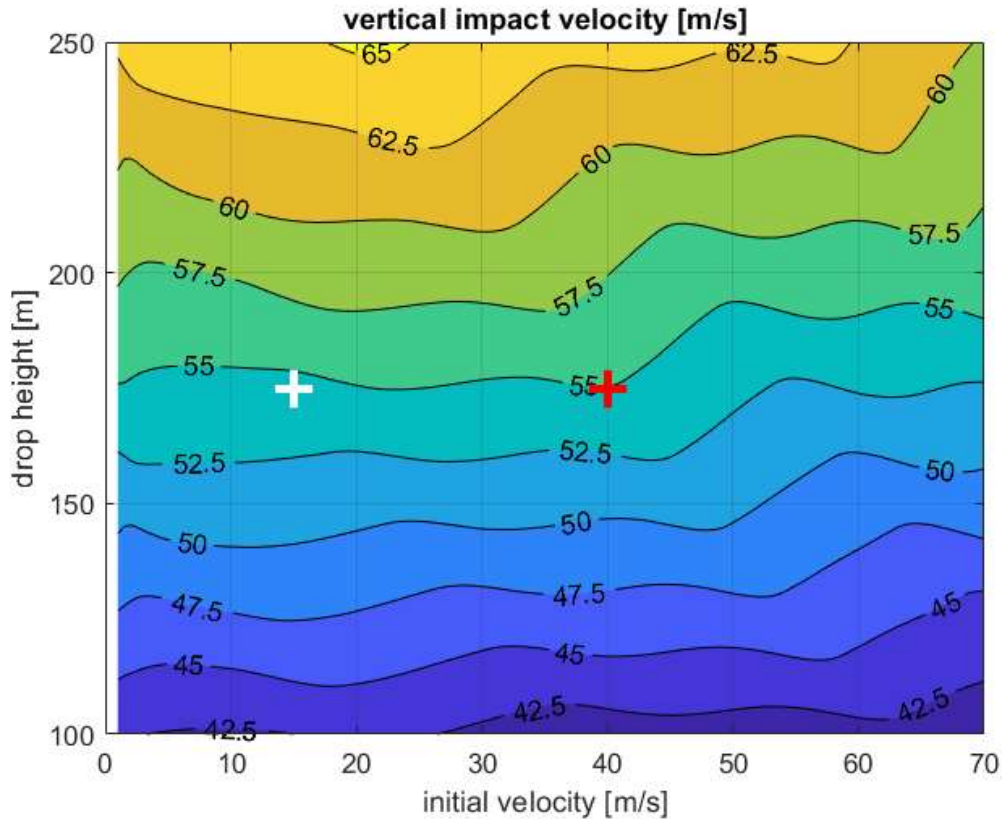

6.257 The figure above shows that vertical impact velocities between 50 and 60 m/s (indicated in the figure by the relevant contour lines) correspond to drop heights between 140 m and 250 m depending on the initial horizontal velocity. This is in line with the minimum drop heights determined in the expert reports commissioned by the FFM.

<sup>228</sup> See “Assessment of impact phenomena at Locations 2 and 4” above.



6.258 The figure below shows results from the same simulations, with the colour representing the pitch angle at impact.

**FIGURE 43: PITCH ANGLE AT IMPACT AS A FUNCTION OF THE INITIAL VELOCITY AND DROP HEIGHT FOR AN INITIAL PITCH ANGLE OF 90° AND A 0°/S PITCH RATE, FOR DROP HEIGHTS BETWEEN 100 AND 250 M, AND INITIAL VELOCITIES FROM 1 TO 70 M/S. THE WHITE MARKER CORRESPONDS TO A DROP HEIGHT OF 175 M AND AN INITIAL VELOCITY OF 15 M/S. THE RED MARKER CORRESPONDS TO A DROP HEIGHT OF 175 M AND AN INITIAL VELOCITY OF 40 M/S.**

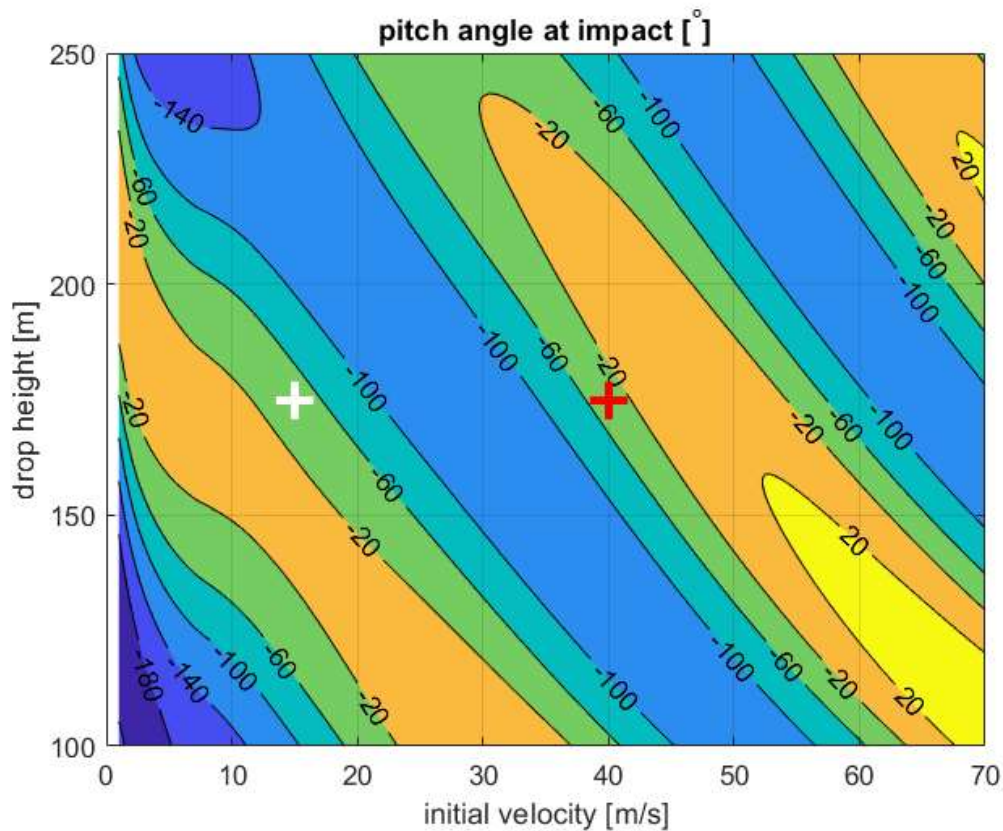

6.259 At Location 2, provided that the cylinder impacted the rooftop floor directly,<sup>229</sup> the pitch angle at impact was  $-45^\circ$ ,<sup>230</sup> with an impact velocity of 55 m/s. This corresponds to a drop height close to 175 m. The figure above further illustrates that for that drop height, initial velocities consistent with a pitch angle at impact of  $-45^\circ$  are close to 15 m/s (white marker) and 40 m/s (red marker).

<sup>229</sup> As noted above, it is impossible to reconstruct whether the cylinder impacted the rooftop floor directly or whether it impacted the wall above the rooftop prior to hitting the rooftop itself. In the latter case, the cylinder would have lost velocity in the prior impact with the wall. However, the change in velocity would be unknown, making it impossible to determine its drop height.

<sup>230</sup> See above: "Assessment of impact phenomena".

- 6.260 At Location 4, the cylinder impacted the roof at a nearly horizontal attitude, consistent with a pitch angle at impact between  $-20^\circ$  and  $+20^\circ$ . In the figure above, this range of pitch angles is indicated by the orange areas. Multiple combinations of drop heights and initial velocities account for impact velocities between 50 and 60 m/s, for which the cylinder would have landed in a nearly horizontal attitude.
- 6.261 The simulation results show that from a height of 175 m the cylinders' impact velocity matches the damage observed at both locations. They further show that it is the initial velocity of the delivery vehicle that may account for differences in the cylinders' attitude at impact. The latter will also differ depending on the initial pitch angle and pitch rate.
- 6.262 For initial pitch angles larger than  $90^\circ$ , and positive pitch rates (i.e. larger than  $0^\circ/\text{s}$ ), even a small change in either would result in a very different attitude at impact. This is illustrated in the figure below.

**FIGURE 44: THE PITCH ANGLE AS A FUNCTION OF TIME FOR A DROP HEIGHT OF 175 M, AN INITIAL VELOCITY OF 10 M/S, AN INITIAL PITCH RATE OF  $20^\circ/\text{s}$  AND TWO INITIAL PITCH ANGLES OF  $101^\circ$  AND  $105^\circ$ .**

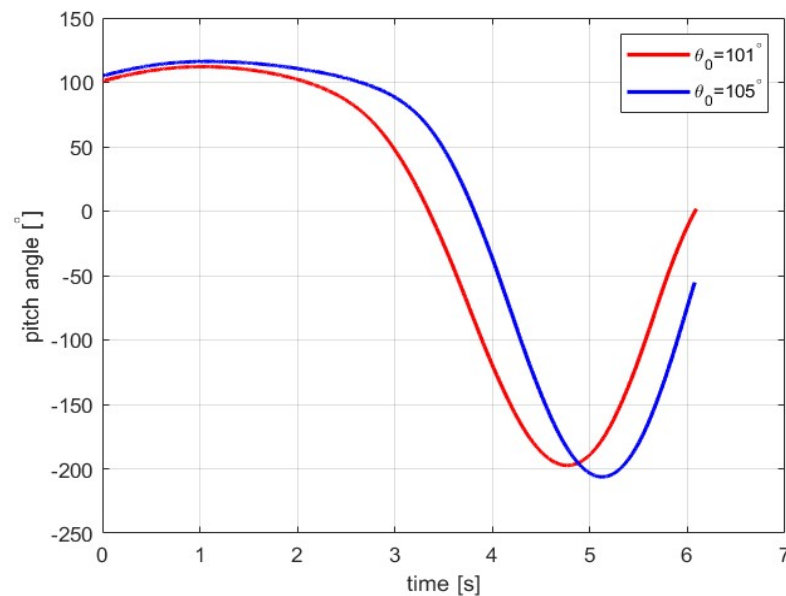

- 6.263 More specifically, the chart above shows two simulation results for which the drop height (i.e. 175 m), the initial horizontal velocity (i.e. 10 m/s) and the initial pitch rate ( $20^\circ/\text{s}$ ) of a cylinder with the same properties as the ones found in Douma are identical. The only value that varies is the initial pitch angle.
- 6.264 A horizontal impact, such as the one established for the cylinder at Location 4, requires an initial pitch angle of  $101^\circ$ . However, a slightly larger initial pitch angle (e.g.  $105^\circ$ ) would suffice for the cylinder to impact nose-down instead, as was the case at Location 2.
- 6.265 A visualisation of why a small change may have such a considerable effect on the cylinder's attitude at impact is provided below.

**FIGURE 45: ILLUSTRATION OF A POSSIBLE TRAJECTORY OF A CYLINDER WITH SIMILAR PROPERTIES AS THE ONES FOUND IN DOUMA (THE CYLINDER IS NOT TO SCALE). THE VISUALISATION IS BASED ON AN INITIAL PITCH ANGLE OF  $101^\circ$ , A DROP HEIGHT OF 175 M, AN INITIAL VELOCITY OF 10 M/S, AND AN INITIAL PITCH RATE OF  $20^\circ/\text{s}$ . THE CYLINDER IS RELEASED AT A HIGH ANGLE OF ATTACK (1), COMES VERY CLOSE TO TUMBLING (2), STARTS TO PITCH DOWN (3), OVERSHOOTS AND BRIEFLY FLIES UP-SIDE DOWN (4), AFTER WHICH IT SWINGS BACK TO IMPACT HORIZONTALLY (5). THE RED ARROWS INDICATE THE DIRECTION OF ROTATION**

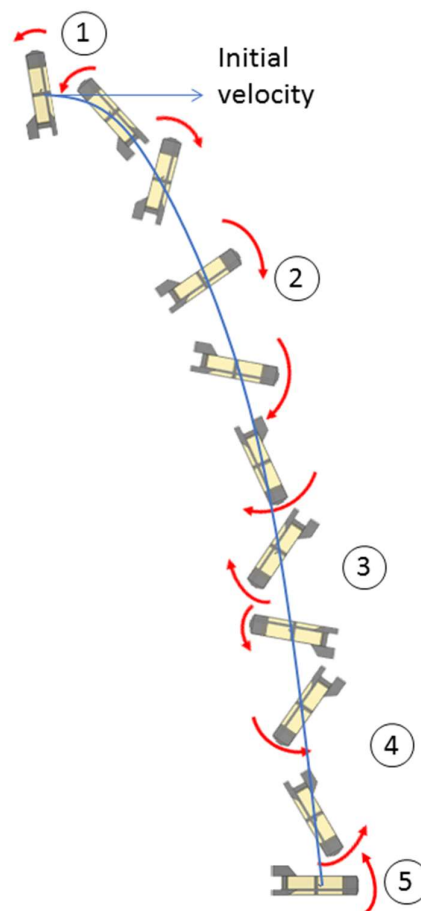

6.266 Due to the positive initial pitch rate and inertia, the cylinder's pitch angle increases at first, even for a cylinder that is assessed to be stable. For low initial velocities, the flight path angle drops very quickly, while the angle of attack increases rapidly. This results in the cylinder pointing backwards in about two seconds, and getting very close to tumbling. However, because the cylinder is stable, the aerodynamic forces acting upon it push its nose down. Then, again due to inertia, the angle of attack overshoots and, about five seconds after having been dropped, the cylinder briefly flies up-side down, after which its nose pitches back up, with the cylinder still swinging upon impact.

- 6.267 If the initial pitch angle is slightly higher, the nose would not yet have pitched up upon impact, resulting in the cylinder hitting nose-down.
- 6.268 The simulation results based on a cylinder with properties representative of the ones found in Douma show that, due to even minor differences in the initial pitch rate or pitch angle, both cylinders may have been dropped at the same initial velocity and from the same height. This is despite their different attitude at impact (i.e. nose-down at Location 2 versus nearly horizontal impact at Location 4), and provided that the cylinder at Location 2 landed on the rooftop floor directly.
- 6.269 For Location 2, the maximum drop height cannot be conclusively determined since it is unclear whether the cylinder impacted the floor directly or hit the rooftop wall first.
- 6.270 For Location 4, an impact velocity of 125 m/s would have resulted in the cylinder penetrating the roof and also, partially, the floor of the bedroom underneath.
- 6.271 Based on the figure below, this would have been possible from a height of about 1,000 m.

**FIGURE 46: VERTICAL IMPACT VELOCITY AS A FUNCTION OF THE INITIAL VELOCITY AND DROP HEIGHT FOR AN INITIAL PITCH ANGLE OF 90° AND A 0°/S PITCH RATE**

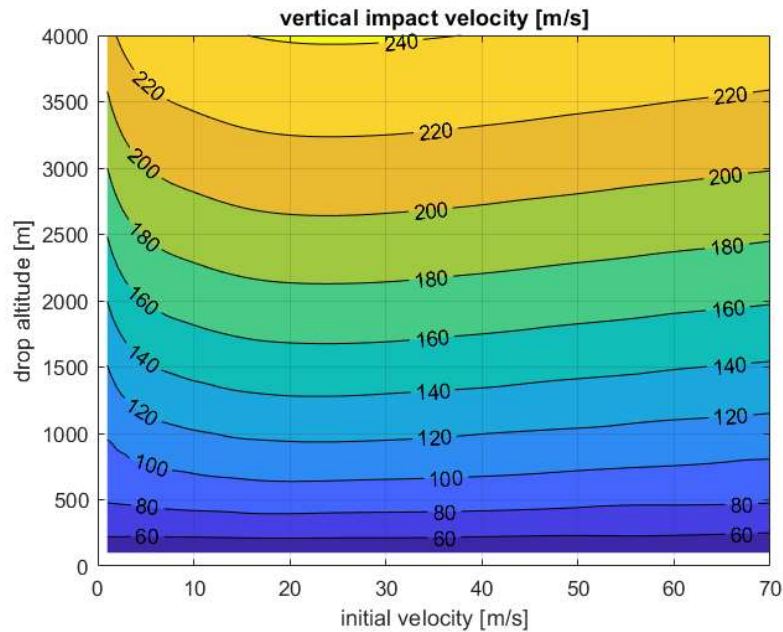

- 6.272 Since the cylinder at Location 4 did not, in fact, breach the bedroom floor, the maximum height at which the cylinder could have been dropped is below 1,000 m.

- 6.273 As noted above,<sup>231</sup> the computer model and the aerodynamics are simplified and the cylinders' parameters are based on estimates. However, while there are (inevitably) limitations to the accuracy of the modelling, none of these significantly affect the relationship between the drop height and the impact velocity.
- 6.274 This also applies e.g. to the possible effects of the cylinders having been partially empty (rather than full of chlorine). Calculations performed by the IIT missile trajectory expert showed that even almost halving the mass of the chlorine in the modelling would not shift the centre of mass far enough for the cylinder to become unstable.
- 6.275 Similarly, whether or not the delivery vehicle was in a climb or a descent does not significantly affect the relation between the drop height and the vertical impact velocity.

### Conclusions

- 6.276 The simulations performed by a missile trajectory expert, supported by the analysis of a terminal ballistics expert, provided the IIT with a scientifically plausible explanation for the delivery of the cylinders found at Location 2 and Location 4.
- 6.277 For Location 2, based on the available information, the IIT assessed that, if the cylinder impacted the rooftop floor directly, it was dropped from a minimum height of 175 m, i.e. from a similar drop height as the one determined for the cylinder found at Location 4. If the cylinder impacted the rooftop wall first, it would have been dropped from even higher, because the impact with the wall would have reduced its vertical velocity. Therefore, a greater drop height would have been required to account for an impact velocity consistent with the damage observed.
- 6.278 The maximum drop height at Location 2 cannot be conclusively determined since it is unclear whether the cylinder impacted the floor directly or hit the rooftop wall first, since—in the latter case—it is impossible to determine how much velocity the cylinder would have lost in the prior impact with the wall.
- 6.279 At Location 4, the impact damage indicates that the cylinder impacted with a vertical velocity between 50 and 60 m/s and, crucially, in a horizontal or nearly horizontal attitude. Trajectory simulations show that these velocities correspond to a minimum drop height for the cylinder of about 140 m above the rooftop level. For a higher strength of the reinforced concrete, the minimum velocity required for the cylinder to breach the concrete roof would have been 72 m/s, pointing to a higher minimum drop height.
- 6.280 The fact that the cylinder impacted horizontally on the bedroom's roof, even though it was stable, indicates that it was dropped with a high initial pitch angle.<sup>232</sup> On the basis of the missile trajectory expert's technical assessment, the IIT concludes that the most likely explanation for that is that the cylinder was dropped by being pushed out of the back of a helicopter, such as an Mi-8/Mi-17, tail-end first.<sup>233</sup> As noted above, while the cabin of most Mi-8/17 variants has clamshell doors at the aft end, underneath the tail

---

<sup>231</sup> See section "Description of the simulation model" above.

<sup>232</sup> See above: "Implications for trajectories".

<sup>233</sup> In this case there would be a small difference between the initial velocity of the cylinder and the velocity of the delivery vehicle.

boom, these helicopters are sometimes flown with these doors removed. If the cylinder is pushed out tail-end first, the tail will go over the edge first, which is consistent with the high initial pitch angle and positive pitch rate determined for Location 4.

- 6.281 The impact damage further indicates, at both locations, a low horizontal velocity at impact, which is incompatible with the cylinders having been dropped by a fixed-wing aircraft, which would be flying at a much higher speed.
- 6.282 As noted above, at Location 4 the cylinder did not penetrate the bedroom floor. In order for the cylinder to do so, an impact velocity of 125 m/s would have been required. This impact velocity could only have been reached if the cylinder had been dropped from a height of approximately 1,000 m. This indicates that the aircraft was flying lower than 1,000 m when the cylinder was dropped.
- 6.283 Based on the results of the analysis of the trajectory alone, the IIT was not in the position to conclusively determine whether the two cylinders were dropped by the same or by two different helicopters.
- 6.284 However, if the cylinder found at Location 2 hit the rooftop floor directly, the locations of the buildings in relation to each other indicate that both cylinders may even have been pushed out of the same helicopter during a single flight over the city. As noted in its Second Report, the IIT obtained information that Mi-8/17 helicopters are able to carry at least two items of the size of the cylinders found in Douma.<sup>234</sup>
- 6.285 At either location, the exact initial velocity, pitch angle and pitch rate of the cylinders would have depended on how fast the latter would have been pushed from the helicopter. Furthermore, the pitch angle at impact would also have been affected by the helicopter's exact height above either rooftop and by small variations in its airspeed, as well as by differences in the exact configuration of the cylinder's assemblies.

#### Assessment of alternative delivery methods

##### *Manual placement*

- 6.286 Despite available evidence, expert reports, and relevant trajectory simulations consistently pointing to both cylinders having been dropped from a low-flying helicopter from heights of at least 140 m, the IIT continued to consider and pursue alternative scenarios throughout the course of its investigation.
- 6.287 In particular, as noted above, the IIT thoroughly reviewed and carefully considered the "Engineering Assessment" that was shared with it in 2019.
- 6.288 According to the "Engineering Assessment", "observations at the scene of the two locations, together with subsequent analysis, suggest that there is a higher probability that both cylinders were manually placed at [the] two locations rather than being delivered from aircraft."<sup>235</sup>

---

<sup>234</sup> Second IIT Report, para. 6.55.

<sup>235</sup> "Engineering Assessment", para. 33.



- 6.289 In the simulations considered in the “Engineering Assessment”, the cylinder penetrates the concrete on the rooftop at Location 2. The main reason for that is the choice of a minimum drop altitude of 500 m in the model.<sup>236</sup> However, the assessment gives no justification for this minimum height. According to the impact calculations included in the “Engineering Assessment”, if dropped from such height, the cylinder should have penetrated the rooftop floor completely, without hitting the wall first. Since the author of the “Engineering Assessment” deems full penetration to be at odds with the observed damage, the “Engineering Assessment” concludes that the cylinder was most likely placed in a pre-existing crater by some unnamed party.<sup>237</sup> However, according to the experts consulted by the IIT, the results presented in the “Engineering Assessment” should, at best, have led its author to conclude that the cylinder, if air dropped, would have been so from a height of less than 500 m. Those results do not support the conclusion that the cylinder could not have been air dropped.
- 6.290 For Location 4, the “Engineering Assessment” concludes that “it was not possible to establish a set of circumstances where the post-deformation cylinder could fit through the crater with the valve still intact.”<sup>238</sup>
- 6.291 The experts consulted by the IIT estimated the overall length of the cylinder’s assembly (including the attached cradle) to be 167.5 cm, which is indeed slightly larger than the 166 cm length of the hole.<sup>239</sup> However, the difference is less than one percent. Furthermore, the fins were clearly bent as a result of the impact on the roof and the tail end of the cradle was torn apart.<sup>240</sup> Based on the IIT experts’ estimates, the damaged assembly would have had a length of approximately 150 cm (i.e. the length of the assembly minus the part of the fins that protrudes beyond the base of the cylinder). This length does include sufficient space for the valve to fit between the top of the cylinder and the front plate of the cradle. This would make the length of the hole consistent with the cylinder landing in a nearly flat attitude and with a fairly slow horizontal velocity. Therefore, the IIT assesses that the hole was large enough for the cylinder to have passed through it.

---

236 “Engineering Assessment”, paras 18, 19.

237 “Engineering Assessment”, paras 17, 18, 19, 21, 23, 32 and 33.

238 “Engineering Assessment”, paras 27.

239 See FFM Report on Douma, Annex 7, page 60, Figures A.7.3 and A.7.4.

240 See FFM Report on Douma, Annex 7, page 63, Figure A.7.8.

**FIGURE 47: CYLINDER FOUND ON THE BED AT LOCATION 4 (SOURCE: FFM)**



- 6.292 Furthermore, despite one of the expert reports commissioned by the FFM describing a detailed scenario in which the cylinder bounces and rotates after penetrating the roof,<sup>241</sup> the “Engineering Assessment” maintained that “it was not possible to establish a set of circumstances that were consistent with observations, which would have resulted” in the cylinder moving laterally within the room after the impact and “bouncing onto the bed.”<sup>242</sup>
- 6.293 As recalled above,<sup>243</sup> the cylinder was found on a bed in the bedroom of the top floor apartment of the building at Location 4.<sup>244</sup> Pictures taken at the scene by both the FFM and by other sources<sup>245</sup> show that the bed was not directly situated under the hole in the roof. Furthermore, the nose of the cylinder points in the opposite direction of the cylinder’s orientation upon impact (as determined above,<sup>246</sup> also based on the fact that the water tank on the roof was not damaged).
- 6.294 Nevertheless, based on the thorough analysis undertaken by the terminal ballistics expert it consulted, the IIT determined that it is conceivable that, after impact, the projectile may have rotated in a vertical plane and bounced off the floor.

---

<sup>241</sup> FFM Report on Douma, page 19, para. 8.34 (“The assessment further indicated that, after passing through the ceiling and impacting the floor at lower speed, the cylinder continued altered trajectory (sic), until reaching the position in which it was found.”).

<sup>242</sup> “Engineering Assessment”, para. 31.

<sup>243</sup> See “Assessment of remnants” section above.

<sup>244</sup> By both the first witnesses that arrived at the scene at around midnight on 8 April 2018 and the FFM during both its first visit to the site on 25 April 2018 and its second visit on 1 May 2018, see FFM Report on Douma, paras 8.32, 8.69, page 40.

<sup>245</sup> All the pictures relied upon by the IIT in the course of its investigation and for the purpose of the present report have been duly authenticated and their metadata verified.

<sup>246</sup> See “Preliminary observation of the scenes” subsection above.

- 6.295 A plausible mechanical explanation of how the cylinder may have landed on the bed after perforating the ceiling is that the cylinder penetrated the roof and, after a partial rotation, impacted on the floor at low velocity. Subsequently, it bounced and (further) rotated. That would explain why the orientation of the cylinder on the bed is opposite to its orientation on impact (about 180°).

**FIGURE 48: POSSIBLE MOTION OF THE CYLINDER IN THE VERTICAL PLANE**

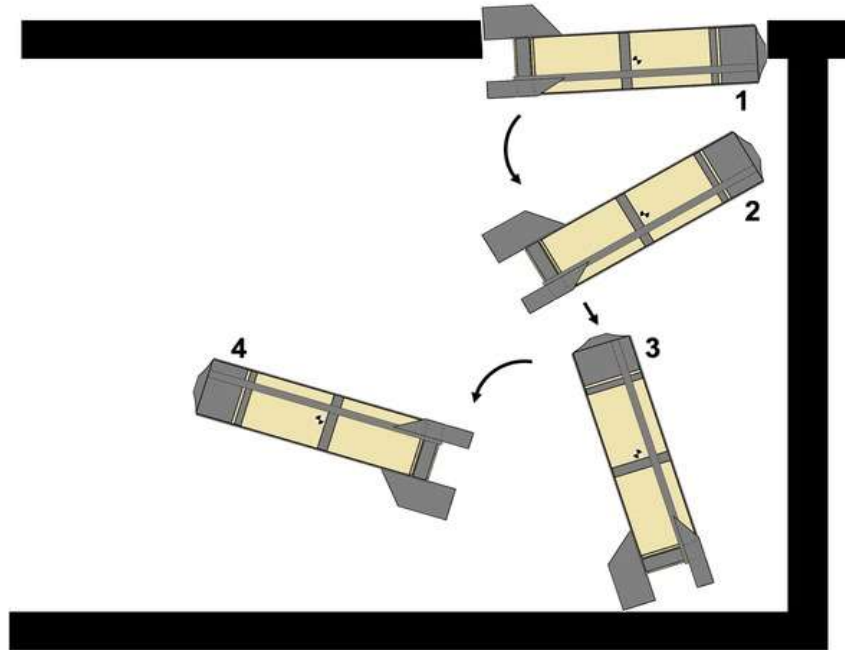

- 6.296 Evidence of the rotation of the cylinder in the bedroom after impact is that the wardrobe is only damaged at the top, most likely because of debris from the crater above. However, the side of the wardrobe was undamaged, which indicates it was not directly hit by the cylinder. Furthermore, the damage visible on the shower unit is consistent with it having been impacted by parts of the cradle.
- 6.297 From visual analysis, the experts consulted by the IIT found no evidence of a hole in the bedroom floor due to the impact of the cylinder, noting, however, that possible minor damage may not have been observed due to debris on the floor. The lack of damage on the bedroom floor as a result of the bouncing of the cylinder tallies with a low velocity of the latter after it lost most of its speed when perforating the bedroom roof. A low velocity after the cylinder perforated the roof is also consistent with Finite Element simulations performed by one of the experts consulted by the FFM.

**FIGURE 49: PICTURE OF DAMAGE TO THE WARDROBE. THE DAMAGE AT THE TOP IS LIKELY CAUSED BY DEBRIS FROM THE CRATER ABOVE, BUT THE SIDE IS OTHERWISE UNDAMAGED, SUGGESTING THAT IT WAS NOT DIRECTLY HIT BY THE CYLINDER**

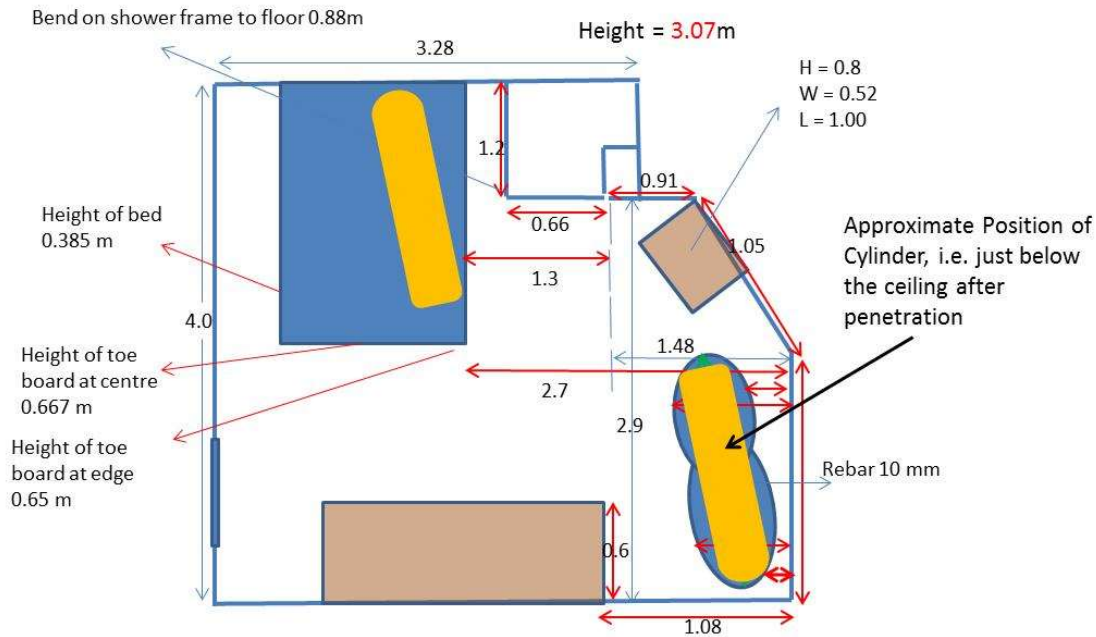

**FIGURE 50: PICTURE OF THE DAMAGED SHOWER UNIT. THE DAMAGE IS LIKELY CAUSED BY PARTS OF THE CYLINDER'S ASSEMBLY (SOURCE: FFM)**



6.298 It is likely that the impact also induced a rotation around the cylinder length axis, which may explain why it moved diagonally across the room. The location in which the cylinder was found is as unlikely as any other location within the room. Moreover, the location in which the cylinder was inspected by the FFM 18 days after the incident does not have a bearing on the cylinder's content and origin.

**FIGURE 51: TOP VIEW OF THE BEDROOM (SOURCE OF BEDROOM LAYOUT AND MEASUREMENTS: FFM)**



6.299 The IIT further notes that the manual placement of the cylinders would have required the heavy<sup>247</sup> and cumbersome<sup>248</sup> cylinder's assemblies to be carried up several flights of stairs, through narrow corridors and, in the case of the cylinder on the roof at Location 2, through a narrow door or through a small window opening. This sequence of actions would have had to have taken place at two different locations, and under the heavy shelling in the days and hours preceding the chemical attack in Douma. Furthermore, it would have had to have gone undetected and/or unnoticed in a densely populated urban area, considering the lack of supporting evidence (photographs, images, satellite/drone imagery) identified or obtained by the IIT.

**FIGURE 52: NARROW DOOR AND WINDOW'S OPENING (SOURCE: FFM)**



<sup>247</sup>

Total mass of 297.4 kg, as estimated by the IIT missile trajectory expert consulted by the IIT.

<sup>248</sup>

167.5 cm long and with three tail fins spanning 75 cm, as estimated by the IIT missile trajectory expert consulted by the IIT.







**FIGURE 54: HEIGHT AND DISTANCE ESTIMATIONS AT LOCATION 4**

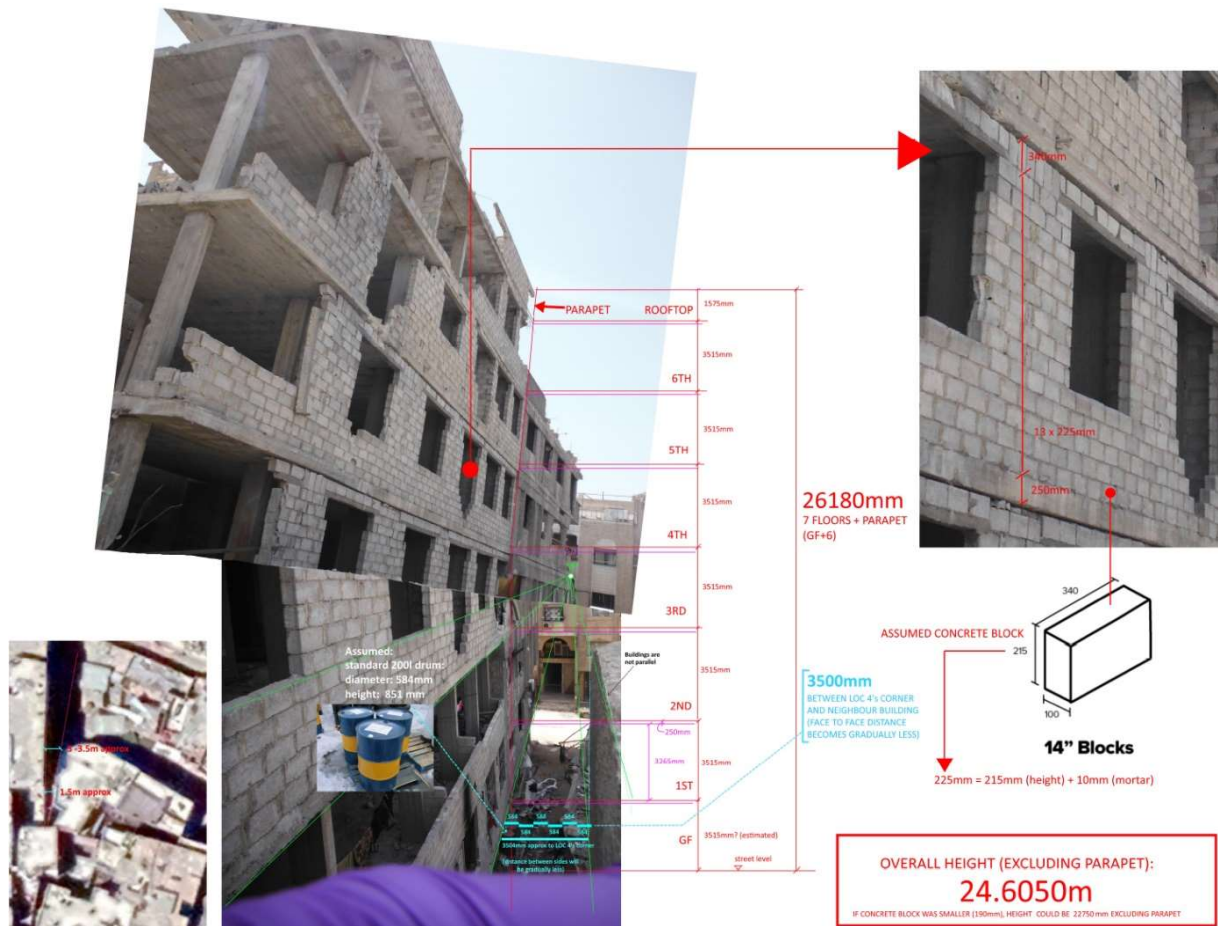

*Other delivery methods*

6.304 The hypotheses that the cylinders may have been delivered by a fixed-wing aircraft or via surface-to-surface artillery have been addressed and discarded above.<sup>252</sup>

**The origin of the cylinders**

6.305 Based on combined assessment by the IIT's munitions, terminal velocity, and missile trajectory experts, the IIT has reasonable grounds to believe that the cylinders found at Location 2 and Location 4 in Douma were dropped by a rotary-wing aircraft (i.e. a helicopter).

6.306 Fourteen witnesses confirmed to the IIT that the attack on Douma was executed between 19:10 and 19:40 on 7 April 2018. Flight observation data reviewed by the IIT, and corroborated by additional sources, show that between 17:40 and 19:04 on the day of the attack no helicopter activity was recorded over Douma or originating from Dumayr airbase. However, helicopter sorties resumed at 19:04, with no less than 11 Mi-8/Mi-17 aircraft being observed circling over Douma between 19:04 and 19:59. In

<sup>252</sup> See above "Conclusions" in this section, and "Assessment of remnants" in the section above.

the time frame assessed as relevant to the attack (i.e. 19:10-19:40), flight observation data shows that at least five Mi-8/17s were seen circling over the city, i.e. one helicopter at 19:10, 19:22 and 19:26 respectively, and then two at 19:38.

- 6.307 The IIT assessed information from seven airbases whose distance from Douma would have been within the range of an Mi-8/17 helicopter.<sup>253</sup> Although all seven bases possessed the capability to support helicopter take-off and the delivery of the munitions, only two out of the seven airbases identified were observed as active on the day of the incident and only one airbase, Dumayr airbase, east of Douma, was observed as active on 7 April 2018 between 19:00 and 20:00.<sup>254</sup>
- 6.308 Records of take-off activity reviewed by the IIT show a significant spike in Mi-8/17 take-offs from Dumayr airbase between February and April 2018. In particular, approximately 90 take-offs of Mi-8/17 helicopters were observed from the airbase on 7 April 2018, i.e. the highest number of daily take-offs recorded during the period analysed.
- 6.309 Satellite imagery obtained by the IIT and interpreted by specialists confirms the sharp increase in Mi-8/17 activity at Dumayr during the same period. On 18 February, two Mi-8/17 helicopters were newly visible on the airbase's central apron. A significant surge in helicopter activity was observed as of 25 March 2018, with seven Mi-8/17 helicopters visible on the airbase's eastern apron, and one Mi-8/17 and three Mi-24 helicopters observed on the western apron.

---

<sup>253</sup> The seven locations assessed included Dumayr Airbase (32 km from Douma), Blay Airbase (also known as Marj Ruhayyil) (31 km), Sin Airbase (82km), Hama Airbase (177 km), Khalkhalah Airbase (58 km), T4 West Airbase (162 km), and the Vehicles School (194 km).

<sup>254</sup> All seven airbases had active runways and hard surface areas with no wing obstruction that would have allowed a Mi-8/17 helicopter to take off. Take off activity was observed at Sin airbase on 7 April 2018 at 15:35.

**FIGURE 55: SATELLITE IMAGERY SHOWING NEWLY VISIBLE MI-8/17 HELICOPTERS AT DUMAYR AIRBASE AS OF 25 MARCH 2018**



6.310 Overall, at least<sup>255</sup> 11 different Mi-8/17s were observed departing from the airbase's eastern and central aprons between 25 March and 11 April. As of 11 April 2018, no helicopter was observed on either the eastern or the western apron of Dumayr.

**FIGURE 56: NO MI-8/17 HELICOPTERS VISIBLE ON THE SAME APRON ON 11 APRIL 2018**

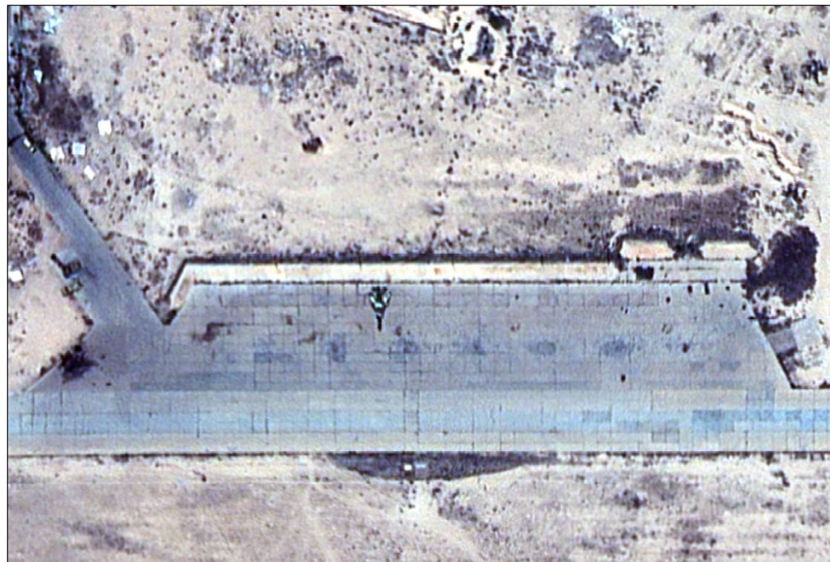

<sup>255</sup>

It should be noted that images are captured by satellite imagery providers at specific hours within the day only. Therefore, the number of aircrafts identified on both aprons at Dumayr Airbase within a given timeframe may not be representative of all aircrafts stationed in the airbase.



- 6.311 Information reviewed by the IIT on the capabilities of the Mi-8/17 helicopter indicates that the fastest flight time between Dumayr Airbase and Douma, had the helicopter travelled in a linear trajectory at maximum speed (i.e. 250 km/h) is approximately 8 minutes.<sup>256</sup> This estimate corroborates the assessment shared with the IIT by witnesses and other sources according to which flight time between Dumayr Airbase and Douma was approximately between 8 to 15 minutes.

**FIGURE 57: DISTANCE BETWEEN DOUMA AND DUMAYR AIRBASE**



- 6.312 Analysis of flight observation data, corroborated by witness statements and other sources, shows that on the evening of 7 April 2018, between 19:00 and 19:40, five Mi-8/17 helicopters took off from Dumayr Airbase flying in a south-westerly direction. Data analysed by the IIT shows that two Mi-8/17 helicopters took off from Dumayr at 19:00. Subsequently, three Mi-8/17 helicopters were observed taking off at 19:09, 19:16, and 19:23 respectively. These take-off times are consistent with the identification (noted above) of five Mi-8/17 helicopters circling over Douma between 19:10 and 19:38, considering the time needed for an Mi-8/17 helicopter to depart from Dumayr and reach (and circle over) Douma.
- 6.313 Mi-8/17 rotary-wing aircraft are operated by several countries. Although this type of helicopter was originally designed for transportation purposes, its large cargo bay—which can store multiple medium-large barrels—makes it particularly suitable for the purpose of delivering both conventional and chemical improvised munitions. As noted in the IIT’s Second Report, Mi-8/17 helicopters are able to carry at least two items of the size of cylinders found at Location 1 and Location 2 in Douma, respectively. Furthermore, the clamshell doors at the aft end of the cabin of most Mi-8/17 variants (which can be removed, as also shown in video and photographic footage from the Syrian conflict) allow the cylinders to be pushed out of the back of the helicopter.

<sup>256</sup> Calculations are based on an approximate distance of 32 km from Dumayr Airbase to Douma, and on the maximum level speed at sea level of an Mi-8/17 helicopter, i.e. 250 km/h. As time equals distance over speed, the time calculated for the flight was 7 minutes and 41 seconds. As noted above, the IIT assesses that the helicopter was flying at a lower speed, see above, “Assessment of the impact and delivery of the munitions”.

- 6.314 Information obtained by the IIT indicates that, in the timeframe in which the incident occurred, the airspace over Douma was exclusively controlled by the Syrian Arab Air Force and the Russian Aerospace Defence Forces. While the IIT assessed information showing that other States carried out airstrikes and operations on the territory of the Syrian Arab Republic in April 2018,<sup>257</sup> it has not obtained any information suggesting that airstrikes were carried out in the eastern Ghouta area (including Douma) by forces opposing the authorities of the Syrian Arab Republic. Further data assessed by the IIT during its investigations confirms that no international coalition aircraft was present in Douma airspace on 7 April 2018.
- 6.315 The IIT has reviewed information from a number of sources indicating that, throughout the eastern Ghouta offensive, both the Syrian Arab Air Force and the Russian Aerospace Defence Force operated Mi-8/17 helicopters in the airspace of the Syrian Arab Republic. However, the IIT has not received conclusive information indicating that the Mi-8/17 helicopters that were observed flying over Douma in the time frame in which the incident occurred were operated by any air force other than the Syrian Arab Air Force.
- 6.316 Specialised sources considered by the IIT (including former pilots, military analysts, and other sources) noted that Mi-8/17 helicopters were modified to support military operations by the Syrian Arab Air Force, both in a transportation capacity and to deploy improvised air delivery munitions.<sup>258</sup> Furthermore, the IIT previously documented the use of Mi-8/17 helicopters by the Syrian Arab Air Force to deploy chlorine-filled cylinders similar to the ones found in Douma in Ltamenah (25 March 2017)<sup>259</sup> and Saraqib (4 February 2018)<sup>260</sup> respectively.
- 6.317 The IIT has received credible information according to which the Syrian Arab Air Force assigned seven Mi-8/17 helicopters to the Tiger Forces. According to reliable sources, the squadron was detached from the 63rd Helicopter Brigade, normally based at Hama airbase.<sup>261</sup>
- 6.318 The IIT has reasonable grounds to believe that the seven helicopters were based at Dumayr Airbase, and operated under the direct command and control of Brigadier-General Souheil al-Hasan. The temporal coincidence between the arrival of the Tiger Forces at Dumayr Airbase on 18 February, and the newly observed presence of two Mi-8/17 helicopters on the airbase's central apron (as captured in satellite imagery from the same day) supports this conclusion.
- 6.319 Despite the assessment that the two cylinders found in Douma on 7 April 2018 were air delivered, the IIT continued to actively pursue the scenario whereby the two chlorine-filled cylinders were carried or delivered to both locations by the 'White Helmets' and/or by members of armed groups, with the support of Western States, in order to "stage" the incident and forge accusations against the Syrian Arab Army. On the basis of its investigations into the matter, and on the technical assessments independently provided by a variety of experts and specialists, the IIT was unable to identify any

---

<sup>257</sup> This includes airstrikes reported on 14 April 2018 by France, the United States of America, and the United Kingdom of Great Britain and Northern Ireland in response to the incident in Douma, and anti-ISIL coalition airstrikes also reported in April 2018.

<sup>258</sup> See e.g. Encyclopedia of World Military Aircraft, Vol. Two., pages 316 – 317.

<sup>259</sup> First IIT Report, paras. 8.36 and 12.31.

<sup>260</sup> Second IIT Report, paragraphs 8.26 and 8.27.

<sup>261</sup> See First IIT Report, para. 6.11.

reliable information (including satellite imagery, video or photographic footage, or intercepts) supporting the allegations of “staging” by armed groups or other entities, or corroborating that any of the required “staging” actions were performed at either location. As mentioned above, the IIT did not obtain any evidence or supporting materials or even concrete leads from the Syrian Arab Republic. Furthermore, no information obtained from other States Parties, pursuant to the requests by the IIT and the Director-General on the basis of paragraph 7 of Article VII of the Convention, or other sources supports the delivery of the cylinders in question by means other than helicopter.



#### **IV. FACTUAL FINDINGS**

##### **7. GENERAL REMARKS**

- 7.1 The IIT scrutinised the information obtained and reached its conclusions on the basis of a holistic assessment through a widely shared methodology, in compliance with the relevant provisions of the Convention, as well as international best practices of international fact-finding bodies and commissions of inquiry.<sup>262</sup>
- 7.2 Throughout the investigation, various hypotheses were considered and pursued. Taking into account the different mandates of the FFM and of the IIT, the IIT was able to expand its sources of information, perform supplementary analyses, and consult additional experts for the specific purpose of identifying the perpetrator of the attack. This allowed for further clarity, consistency, and corroboration as to what witnesses and the original chemical analyses had indicated about the origins of the chlorine identified by the FFM at the two locations.
- 7.3 The IIT holistically assessed all of the information it obtained, taking a critical approach against the posited scenarios, keeping an open mind, and encouraging States Parties—including the Syrian Arab Republic—and other entities to contribute to expanding its evidentiary basis.
- 7.4 As the investigation progressed, some scenarios appeared increasingly less likely, as they could not be substantiated through, nor reasonably explain, the information obtained from a variety of distinct sources, taken as a whole. As a result of its investigation, the IIT could not identify any plausible explanation for the concurrence of information before it, other than the conclusions presented below.

##### **8. FACTUAL FINDINGS ON THE INCIDENT OF 7 APRIL 2018**

- 8.1 In relation to the incident of 7 April 2018, in light of the information obtained considered in its totality, the IIT concludes that there are reasonable grounds to believe that between 19:10 and 19:40 (UTC +3) on 7 April 2018, during a major military offensive aimed at regaining control of the city of Douma, at least one Mi-8/17 helicopter of the Syrian Arab Air Force, departing from Dumayr airbase and operating under the control of the Tiger Forces, dropped two yellow cylinders which hit two residential buildings in a central area of the city.
- 8.2 At Location 2, the cylinder hit the rooftop floor of a three-storey residential building without fully penetrating it, ruptured, and rapidly released toxic gas—chlorine—in very high concentrations, which rapidly dispersed within the building, killing 43 named individuals and affecting dozens more.

---

<sup>262</sup> See below, Annex 2.

- 8.3 At Location 4, the cylinder hit the roof of a three-storey residential building (at that time uninhabited) and broke into the apartment below, landing on a bed after bouncing off the floor. The cylinder ruptured only partially, and started to slowly release chlorine, mildly affecting those who first arrived at the scene.
- 8.4 The IIT has reached this conclusion by applying a holistic approach to the assessment of the information related to the different hypotheses it pursued during its investigation.
- 8.5 As noted above, while chlorine has many legitimate uses, gaseous chlorine is poisonous and is classified as a pulmonary irritant—its toxicity being a function of dosage and exposure time.
- 8.6 In light of the analytical results presented above, the IIT has reasonable grounds to believe that chlorine gas was used at both relevant locations in Douma, and that the cylinders were the origin of the chlorine gas released at both locations.
- 8.7 For both Location 2 and Location 4, the review of the analytical data of 68 samples collected on site by the FFM and the analysis of two additional samples revealed the presence of chlorine gas markers whose formation and specific position at both sites can solely be explained by the release of high concentrations of chlorine gas from the cylinder. This allowed the IIT to rule out the hypothesis that the incident may have been “staged” using household bleach products or pesticides, or that no chemical event may have taken place at all. At the two sites, identical chemical fingerprints were identified in conifer wood present in the basement of Location 2 and in the bed at Location 4, as a result of its exposure to chlorine gas.
- 8.8 At Location 2, the presence of highly chlorinated phenols (TCP and TeCP) in samples collected close to the cylinder points to the release of chlorine gas at high concentrations. The gradient of the chlorinated agents—from the highly chlorinated phenols at the crater and the room under the cylinder, to the low-chlorinated phenols present on the street—further supports this conclusion.
- 8.9 Similarly, at Location 4, the conifer wood samples from the bed under the cylinder were exposed to very high levels of chlorine gas. This is consistent with the presence of the highly chlorinated phenol TeCP in a number of other samples collected close to the cylinder, further indicating a high concentration of chlorine gas.
- 8.10 The presence of the chlorine signature of the two chlorinated chemicals BC and TCP in conifer wood samples from both Location 2 and 4 creates a link between the events of release of chlorine gas in the two buildings.
- 8.11 The IIT notes that, while the Syrian Arab Republic did not grant it access to the locations in question, the information and analytical findings supporting the FFM Report (based on samples collected between 14 and 18 days after the incident in accordance with the relevant procedures of the Secretariat),<sup>263</sup> in combination with additional evidence obtained, were sufficient to reach solid conclusions, to the requisite degree of certainty.

---

<sup>263</sup> See Note by the Secretariat S/1755/2019 (dated 21 May 2019) “Update on the OPCW Fact-Finding Mission in Syria”, Annex 1, p. 8.

- 8.12 The IIT reiterates that it has carefully assessed all information provided by States Parties and thoroughly pursued the relevant lines of inquiry, particularly in relation to the hypothesis that the incident of 7 April 2018 in Douma may have been “staged” by using household bleach products or pesticides in order to resemble an area affected by a chlorine gas attack. However, the “staging” scenario finds no support in the chemical data considered in their totality, nor in the pattern of how the relative levels of the chlorinated chemicals are distributed.
- 8.13 The IIT determined that, at both locations, it would have been extremely difficult, if not impossible, to mimic the spread of a gas such as chlorine gas. Laborious “staging” operations would have had to be performed according to a detailed plan in order to produce the exact concentration gradient and pattern observed in the results, at two different locations. The IIT was unable to identify any evidence, including from open-source information or from the Syrian Arab Republic or other States Parties, which would corroborate that any of the aforementioned staging actions were performed at either location. The unavailability, at the time of the incident, of scientific information about both BC and TCP production in conifer wood exposed to chlorine gas makes the “staging” scenario even more implausible.
- 8.14 Furthermore, it would have been impossible to foresee what samples the FFM inspectors would have collected, and from where, at each location. In all of the data resulting from the chemical analysis of the samples collected at both locations, there were no outliers, i.e. no samples displayed a result that was inconsistent with the hypothesis that chlorine gas was released from the cylinders found at both locations.<sup>264</sup>
- 8.15 The symptoms of the victims are, overall, consistent with exposure to chlorine gas in very high concentrations. Following the assessment and corroboration of the relevant material, the toxicologist consulted by the IIT reached the conclusion that the accounts of the victims and medical personnel were consistent with the rapid release of a high dosage of chlorine gas, which led to the rapid and high fatality rate documented at Location 2.
- 8.16 The two independent gas dispersion models considered by the IIT for Location 2 indicate that the accounts of the witnesses and the rapidity at which the symptoms began are indeed reliable, and that those persons were affected by chlorine gas used as a weapon. In particular, those who died in the building at Location 2 did so as a result of the exposure to chlorine gas released rapidly from the rooftop. The IIT further assesses that several among the fatalities were exposed to chlorine while seeking to escape from their shelter in the basement to upper floors, as per the common protocol “to head to

---

<sup>264</sup> The IIT notes that this conclusion is consistent with the assessment of a number of States Parties, e.g. Letter dated 20 May 2019 from the Permanent Representative of the Russian Federation to the United Nations addressed to the Secretary-General and the President of the Security Council, Annex I (“Aide-memoire from the Russian Federation on Russian assessments of the report of the Organisation for the Prohibition of Chemical Weapons fact-finding mission in the Syrian Arab Republic regarding an incident in which toxic chemicals were alleged to have been used as a weapon in Douma, Syrian Arab Republic, on 7 April 2018”), A/73/883-S/2019/415, 23 May 2019, page 5 (“[t]he Russian Federation does not contest the findings in the report that the cylinders may have contained molecular chlorine”); Permanent Mission of the Syrian Arab Republic to the OPCW, Note Verbale No. 68 dated 9 July 2021 (referring to the cylinders related to the incident in Douma as “two chlorine cylinders”).

higher ground in the event of chemical attacks”.<sup>265</sup> This is consistent with the majority of the fatalities being observed on the first and second floors of the building, and on the internal stairwell.

- 8.17 At Location 4, the absence of severe symptoms and fatalities—compared to those reported at Location 2 and in the surrounding area—can be explained by fact that the relevant building was not inhabited at the time the incident occurred, and that the valve of the cylinder found at Location 4 did not rupture (unlike the one at Location 2). That is consistent with a slow and steady release of chlorine gas from the cylinder.
- 8.18 In view of the alternative scenarios pursued during its investigations, the IIT assessed whether some of the symptoms reported (e.g. contorted limbs and involuntary urination/defecation) may have been a direct result of a chemical agent other than chlorine, concluding that those symptoms were consistent with hypoxia-induced seizure activity. In addition, in line with the chemistry findings, the toxicology assessment concluded that the analytical data underlying the FFM Report on Douma, which included blood samples, does not support evidence of any types of chemical compounds except for chlorine.
- 8.19 Finally, with regard to the alternative scenario in which the fatalities would have been killed elsewhere and subsequently moved to Location 2 in an attempt to “stage” an attack, the IIT notes that signs of blunt-force trauma or penetrating trauma are not visible in any of the fatalities observed in verified videos and images from Location 2, and that neither witnesses nor medical personnel recount observing blunt-force trauma or penetrating trauma in any of the fatalities, and that those signs are not observed in verified videos and images from Location 2 either. Furthermore, fully established rigor mortis, observed in fatalities being carried out of Location 2 in the early hours of 8 April 2018, indicates that the time since death was no more than approximately 9 to 16 hours. The IIT also notes that it did not obtain from the Syrian Arab Republic or other States Parties, nor was it able to identify, any evidence—including videos, photographs, satellite or drone imagery, open-source information etc.—which would corroborate that the aforementioned staging actions were performed at Location 2.
- 8.20 The IIT has reasonable grounds to believe that the cylinders observed at both Location 2 and Location 4 were intended to be used as air-delivered munitions.
- 8.21 Design features of both cylinders, as well as of the metal cradles fitted to them, indicate that they were intended to be delivered via aircraft.
- 8.22 Furthermore, the orientation of the lifting lugs on the metal cradles found at both locations indicates that the cylinders were not designed to be attached to the outside weapons pylon of an aircraft, but rather to be pushed out of the cargo bay of either a rotary-wing (i.e. helicopter) or fixed-wing aircraft. The presence at both locations of wheels mounted onto axles, which are intended to facilitate the handling of the cylinders, further supports this hypothesis.

---

<sup>265</sup> Witnesses interviewed by the IIT recounted that the knowledge of chemical weapons protocols is particularly widespread in eastern Ghouta (among medical doctors, first responders, and the civilian population alike) as a result of the vivid memories of—and trauma caused by—the chemical attack carried out in Zamalka (eastern Ghouta) on 21 August 2013 (i.e. the deadliest use of chemical weapons documented in the Syrian conflict); see “General situation in the area” section above.

- 8.23 Mi-8/17 helicopters are particularly suitable for the purpose of delivering medium and large conventional and chemical improvised munitions, due to their large cargo bay, which can store multiple medium-large barrels. This is consistent with the findings reached by the IIT in both its First and its Second Report, in which it concluded that chlorine-filled cylinders similar to the ones found in Douma were dropped by Mi-8/17 helicopters operated by the Syrian Arab Republic in Ltamenah and Saraqib.
- 8.24 At Location 2, the damage observed on the cylinder was consistent with what would have been expected from the drop from an aircraft, rather than e.g. from an adjacent building. Traces of dried condensation droplets, observed on the cylinder's shell, are consistent with condensation resulting from auto-refrigeration, which, in turn, is in line with the rapid release of gas from the sheared-off valve of the cylinder at Location 2. The significant corrosion observed on the metal cradle further supports the hypothesis of chlorine release from the cylinder, as well as the chemistry findings made by the IIT.
- 8.25 At Location 4, the overall damage to the cylinder indicates that it was air delivered and impacted horizontally. Visible signs of corrosion on the cylinder—whose valve was not sheared off—are consistent with the slow release of chlorine, as well as with analogous patterns of corrosion observed on similar cylinders used in other incidents of use of chlorine as a chemical weapon (e.g. Kafr Zeita, 1 October 2016).
- 8.26 No indication was found at either location that explosives had been used to ensure the release of the cylinders' content.
- 8.27 The possibility that the cylinders may have been delivered by surface-to-surface weapons, i.e. IRAMs or improvised artillery, was also ruled out. Both cylinders were significantly larger than the IRAMs documented in the Syrian context and lacked any signs that a rocket motor was attached to them. Furthermore, the design of both munitions makes it highly unlikely, if not impossible, that they may have been launched using improvised mortars. Finally, no remnants, footage or any other evidence obtained by the IIT supports the hypothesis of surface-to-surface (rather than air) delivery.
- 8.28 The hypothesis of manual placement at both locations is inconsistent with the damage observed on both cylinders, as well as with the totality and consistency of the evidence obtained and analyses performed in relation to both sites.
- 8.29 Based on almost 80,000 simulations of trajectories, the IIT assessed that, at Location 2, if the cylinder impacted the rooftop floor directly, it would have been dropped from a minimum height of 175 m, and from even higher if the cylinder impacted the rooftop wall first. In this case, the impact with the wall would have reduced its vertical velocity, requiring a greater drop height to account for an impact velocity consistent with the damage observed.
- 8.30 The maximum drop height at Location 2 cannot be conclusively determined since it is unclear whether the cylinder impacted the floor directly or hit the rooftop wall first. In the latter case, it is impossible to determine how much velocity the cylinder would have lost in the prior impact with the wall.
- 8.31 At Location 4, the impact damage indicates that the cylinder impacted with a low vertical velocity and in a horizontal or nearly horizontal attitude, with trajectory simulations pointing to a minimum drop height of about 140 m above the rooftop level

(or higher in case of higher strength of the reinforced concrete). Based on the experts' technical assessment, the IIT has reasonable grounds to believe that the most likely explanation for the cylinder having impacted horizontally on the bedroom's roof, despite being stable, is that it was dropped with a high initial pitch angle. This provides a strong indication that the cylinder was pushed out of the back of a helicopter, tail-end first.<sup>266</sup> As noted above, most Mi-8/17 variants have clamshell doors at their aft end, but can fly with these doors removed, which makes them ideal for the purposes of deploying munitions during flight.

- 8.32 The damage observed further indicates a low horizontal velocity at impact, which is incompatible with the cylinder having been dropped by a fixed-wing aircraft. The fact that the cylinder at Location 4 did not penetrate the bedroom floor points to an impact that could only have been reached if the cylinder had been dropped from a height of approximately 1,000 m. The IIT has therefore reasonable grounds to believe that the cylinder was dropped by an aircraft that was flying lower than 1,000 m when the cylinder was dropped.
- 8.33 The IIT has taken into due account various official communications from the Russian Federation pointing out that helicopters operated by the Syrian Arab Air Force do not fly over human settlements at altitudes below 2,000 m, in order to prevent being fired at and/or shot down.<sup>267</sup> In its First Report, the IIT acknowledged that “the use of helicopters during the day posed risks in terms of the helicopter itself becoming a visible target for ground enemy fire due to its distinct features and lower speed than fixed-wing aircraft.”, and suggested that “such risks would be mitigated by an altitude of about 4,000 m”.<sup>268</sup>
- 8.34 However, also based on consultations with military analysts and helicopter pilots, the IIT notes that a flight height of up to 1,000 m would be fully consistent with the technical specifications of the helicopters observed circling over Douma during the time frame identified for the attack. The IIT further notes that the rotary-wing aircraft which delivered the cylinders would have flown after sunset (i.e. not during daytime, as was the case with the incident of 25 March 2017 in Ltamenah), and in a highly volatile operational context, characterised by intense air traffic in the airspace over Douma. The IIT has also received credible information that, earlier in the conflict, Jaysh al-Islam had managed to seize an OSA surface-to-air missile system from the Syrian Arab

---

<sup>266</sup> In this case there would be a small difference between the initial velocity of the cylinder and the velocity of the delivery vehicle.

<sup>267</sup> See Permanent Representation of the Russian Federation to the Organisation for the Prohibition of Chemical Weapons, Note Verbale No. 759 (dated 26 April 2019) requesting circulation of the Russian Federation's paper “Commentaries on the conclusion of the report of the Fact-Finding Mission on the use of chemical weapons in Syria regarding the alleged use of chemical weapons in Douma on 7 April 2018” as an official-series document of the Ninetieth Session of the OPCW Council, page 5, para 2(a); Letter dated 20 May 2019 from the Permanent Representative of the Russian Federation to the United Nations addressed to the Secretary-General and the President of the Security Council, Annex I (“Aide-memoire from the Russian Federation on Russian assessments of the report of the Organisation for the Prohibition of Chemical Weapons fact-finding mission in the Syrian Arab Republic regarding an incident in which toxic chemicals were alleged to have been used as a weapon in Douma, Syrian Arab Republic, on 7 April 2018”), A/73/883-S/2019/415, 23 May 2019, p. 4; “Statement by H. E. Ambassador Alexander Shulgin, Permanent Representative of the Russian Federation to the OPCW at an Arria-Formula Meeting of UNSC Member States on the Implementation of UNSCR 2118 – OPCW FFM Report on Douma”, EC-93/NAT.4 (dated 12 February 2020), page 6.

<sup>268</sup> First IIT Report, para. 8.20.



Armed Forces. However, the IIT understands that the system was no longer in use at the time of the incident in Douma. The IIT further notes that, despite its requests for information, it has not received any official flight data relevant to the incident from either the Syrian Arab Republic or the Russian Federation.

- 8.35 Based on the results of the analysis of the trajectory alone, the IIT was not in the position to conclusively determine whether the two cylinders were dropped by the same or by two different helicopters. However, if the cylinder found at Location 2 hit the rooftop floor directly, the locations of the buildings in relation to each other indicate that both cylinders may even have been pushed out of the same helicopter during a single flight over the city. As noted in its Second Report, the IIT obtained information that Mi-8/17 helicopters are able to carry at least two items of the size of the cylinders found in Douma.<sup>269</sup>
- 8.36 Based on the expert assessment of the overall length of the cylinder's assembly (including the attached cradle) and of the hole in the roof at Location 4, the IIT also assesses that the hole was large enough for the cylinder to have passed through it, thus countering one of the main arguments supporting the "staging" scenario. Similarly, based on the thorough analysis undertaken by the terminal ballistics expert it consulted, the IIT determined that it is possible that, at Location 4, after impact, the cylinder may have rotated in a vertical plane and bounced off the floor onto the bed in the room. A full mechanical explanation is provided above.<sup>270</sup>
- 8.37 Based on combined assessment by the IIT's munitions, terminal velocity, and missile trajectory experts, the IIT has reasonable grounds to believe that the cylinders found at Location 2 and Location 4 in Douma were dropped by a helicopter.
- 8.38 Fourteen witness statements allowed the IIT to situate the attack on Douma between 19:10 and 19:38 (UTC+3) on 7 April 2018. In that time frame, flight observation data shows that at least five Mi-8/17 were seen circling over the city.
- 8.39 The IIT has assessed that, out of the seven airbases whose distance from Douma would have been within the range of an Mi-8/17 helicopter, Dumayr airbase was observed as active in the relevant time frame.
- 8.40 Satellite imagery and records of take-off activity obtained by the IIT show a significant spike in Mi-8/17 take-offs from Dumayr airbase between February and April 2018, with approximately 90 take-offs of Mi-8/17 helicopters observed from the airbase on the day of the incident in Douma. Satellite imagery obtained by the IIT and interpreted by specialists confirms the sharp increase in Mi-8/17 activity at Dumayr during the same period. The IIT has assessed the flight time between Dumayr airbase and Douma to be between 8 to 15 minutes.
- 8.41 Analysis of flight observation data, corroborated by witness statements and other sources, shows that on the evening of 7 April 2018, between 19:00 and 19:40, five Mi-8/17 helicopters took off from Dumayr airbase flying in a south-westerly direction. The IIT found that the relevant take-off times are consistent with the observation of five Mi-8/17 helicopters circling over Douma between 19:10 and 19:38,

---

<sup>269</sup> Second IIT Report, para. 6.55.

<sup>270</sup> See "Assessment of impact and delivery of the munitions" section above.

considering the time needed for an Mi-8/17 helicopter to depart from Dumayr and reach (and circle over) Douma.

- 8.42 Information obtained by the IIT from spotters, witnesses, military analysts, and other sources indicates that, in the time frame in which the incident occurred, the airspace over Douma was exclusively controlled by the Syrian Arab Air Force and the Russian Aerospace Defence Force. The IIT has not obtained any information suggesting that air strikes were carried out on the eastern Ghouta area (including Douma) by forces opposing the authorities of the Syrian Arab Republic. Further data assessed by the IIT during its investigations confirm that no international coalition aircraft were present in the Douma airspace on 7 April 2018.
- 8.43 While, throughout the eastern Ghouta offensive, both the Syrian Arab Air Force and the Russian Aerospace Defence Force operated Mi-8/17 helicopters, the IIT has not received conclusive information indicating that the Mi-8/17 helicopters that were observed flying over Douma during the time frame in which the incident occurred were operated by any air force other than the Syrian Arab Air Force. Furthermore, the IIT has previously documented the use of Mi-8/17 helicopters by the Syrian Arab Air Force to deploy chlorine-filled cylinders similar to the ones found in Douma in Ltamenah<sup>271</sup> and Saraqib.<sup>272</sup>
- 8.44 The IIT has received credible information according to which the Syrian Arab Air Force assigned a squadron of seven Mi-8/17 helicopters to the Tiger Forces, likely to have been detached from the 63rd Helicopter Brigade.
- 8.45 The IIT has reasonable grounds to believe that the seven helicopters were based at Dumayr airbase and operated under the direct command and control of Brigadier-General Souheil al-Hasan. The temporal coincidence between the arrival of the Tiger Forces at Dumayr airbase on 18 February, and the newly observed presence of two Mi-8/17 helicopters on the airbase's central apron (as captured in satellite imagery from the same day) supports this conclusion.
- 8.46 Given the intense traffic of Syrian and Russian military aircraft in Douma's airspace during the time frame in which the incident occurred<sup>273</sup> (as confirmed to the IIT by witnesses, spotters, and other sources) and the fact that the IIT has not obtained any official flight data from either the Syrian Arab Republic or the Russian Federation (despite the Secretariat's outreach),<sup>274</sup> the IIT has been unable to conclusively determine to the requisite degree of certainty whether the attack was carried out by one Mi-8/17 helicopter (carrying two cylinders) in one sortie, or by two different helicopters, each carrying one cylinder. As noted above, the large cargo bay of an Mi-8/17 may well have allowed a single helicopter to deliver two cylinders of the size of those used in Douma.

---

<sup>271</sup> First IIT Report, paras 8.36 and 12.31.

<sup>272</sup> Second IIT Report, paras 8.26 and 8.27.

<sup>273</sup> Information obtained by the IIT shows that between 18:00 and 21:00, 10 L-39s, four Sukhoi Su-22s, and two Sukhoi Su-24s (Fencer) were observed circling over Douma.

<sup>274</sup> See Annex 3.

- 8.47 Similarly, the IIT has reviewed information from different sources (including witnesses, open sources, and States Parties) pointing to a specific call sign<sup>275</sup> (“Dika 427”) associated with the helicopter that carried out the attack. The IIT has considered the alleged transcript of a radio communication between that call sign and Dumayr that occurred on the night of the incident, but was unable to conclusively link it to the specific sortie(s) associated with the chemical attack. Furthermore, the IIT notes inconsistencies between the time of the alleged communication and the time frame it identified for the attack.
- 8.48 Other call signs were also brought to the IIT’s consideration, but their relevance to the incident could not be independently verified.
- 8.49 The IIT did not obtain any information indicating that military targets had been placed in the proximity of either Location 2 or Location 4. While some witnesses suggested that the “Point 1” Hospital may have been the target of the attack (given its proximity to Location 2), the IIT was not in the position to corroborate this information. The IIT further notes that the inherently imprecise and indiscriminate nature of the cylinders used in the attack would have made it almost impossible to predict which specific area they would have hit. Therefore, it is highly unlikely that specific structures could have been reliably targeted in the attack.
- 8.50 Credible information obtained by the IIT indicates the presence of a barrel bomb production or loading facility at Dumayr airbase at the time of the incident of 7 April 2018. Satellite imagery, analysed by specialists, did not confirm the specific presence or transport of chemical weapons during the relevant period. However, it showed the presence of several infrastructures at the airbase that would have been suitable for the storage of the relevant equipment.
- 8.51 The IIT has received credible information from at least two sources that, in the early evening of 7 April 2018, Syrian military officials based at Dumayr discussed the use of chlorine-filled munitions on the same evening. According to the same sources, the munitions were requested by Brigadier General Souheil Al-Hassan. The request was subsequently transmitted by the Chief of the Syrian Air Force Intelligence, Major-General Jamil Hassan, to an officer of the Syrian Air Force Intelligence, who coordinated the delivery and loading of the munitions.
- 8.52 This account is consistent with the information noted in the Second IIT Report, indicating that, at that time of the hostilities, the use of chlorine as a weapon by the Syrian Arab Army was delegated to operational level commanders<sup>276</sup> against discrete targets and armed opposition groups. However, the IIT could not corroborate this information to the requisite degree of certainty, and therefore did not rely on it.
- 8.53 While the IIT could not draw definitive conclusions, to the requisite degree of certainty, as to the specific chain of command for the specific orders issued in relation to the incident of 7 April 2018, it recalls the information it obtained regarding the Tiger

---

<sup>275</sup> I.e. “Dika-427”.

<sup>276</sup> See Second IIT Report para. 9.3.

Forces' involvement in requesting chlorine to use as a chemical weapon in Ltamenah on 25 March 2017<sup>277</sup> and in Saraqib on 4 February 2018.<sup>278</sup>

- 8.54 The IIT further notes that whilst the Russian Federation, and notably the Russian Aerospace Defence Force, was actively engaged throughout the eastern Ghouta offensive, and operated in close coordination with the Syrian Arab Air Force and the Tiger Forces at the operational and tactical levels, the IIT has not obtained any information indicating the involvement in the incident of 7 April 2018 in Douma of any States Parties other than the Syrian Arab Republic.
- 8.55 Until the final stages of its investigations, the IIT continued to actively pursue the scenario whereby the two chlorine-filled cylinders were carried or delivered to both locations by the “White Helmets” and/or by members of armed groups, with the support of Western States, in order to “stage” the incident and forge accusations against the Syrian Arab Army. However, the IIT was unable to identify any reliable information (including satellite imagery, video or photographic footage, intercepts etc.) supporting the allegations of “staging” by armed groups or other entities with no aerial assets in Douma in April 2017, or corroborating that any of the required “staging” actions were performed at either location. As mentioned above, the IIT did not obtain any supporting evidence from either the Syrian Arab Republic or the Russian Federation. Furthermore, no information obtained from other States Parties, pursuant to the requests by the IIT and the Director-General on the basis of paragraph 7 of Article VII of the Convention, or from other sources supports the delivery of the cylinders in question by means other than helicopter.

## 9. GENERAL CONCLUDING OBSERVATIONS

- 9.1 The IIT notes public statements and official communications by the Syrian authorities and other States Parties related to internal investigations that could be relevant to the use of chemical weapons in Douma on 7 April 2018.<sup>279</sup> However, the IIT did not obtain or receive any information, though it requested it, as to investigations and prosecutions by the Syrian authorities regarding the incident in Douma of 7 April 2018, as

---

<sup>277</sup> First IIT Report, para. 8.10.

<sup>278</sup> Second IIT Report, para. 5.14.

<sup>279</sup> See Permanent Mission of the Syrian Arab Republic to the OPCW, Note Verbale No. 44 dated 4 May 2018 (“Therefore we wish to inform you that after having informed the Fact Finding Mission and given the importance of compiling and retaining technical and forensic evidence, the National Authority has moved and stored these two cylinders in a secure location with a view to pursuing the investigation concerning those who have used these two cylinders.”). See also Annex to the letter dated 17 May 2018 from the chargé d’affaires a.i. of the Permanent Mission of the Russian Federation to the United Nations addressed to the Secretary General—Statement by the President of Russia, Vladimir Putin, dated 14 April 2018 (S/2018/472, dated 18 May 2018) (; see AFP, “Syria Chemical Attack “Staged” with help of foreign secret service: Russia” (quoting the Minister of Foreign Affairs of the Russian Federation stating that “[w]e have irrefutable evidence that this was another staged event”); and <https://apnews.com/article/chemical-weapons-russia-ap-top-news-syria-middle-east-aa5d345988a64422a2b1cb7f5ddc41f8> (quoting Maj. Gen. Yuri Yevtushenko, head of the Russian Centre for Reconciliation of Opposing Sides in Syria stating that “According to the results of a survey of witnesses, studying samples and investigating locations undertaken by Russian specialists and medical personnel in the city of Douma, where chemical weapons purportedly were used, the use of poisonous substances was not shown.”).

required under Article VII of the Convention<sup>280</sup>—proceedings which in any case would not affect the mandate of the IIT.

- 9.2 During this investigation, the IIT also did not obtain any information that would indicate that rogue units or individuals used chemical weapons in this incident in the manner described above.
- 9.3 The IIT obtained information from various sources suggesting that, for chemical weapons to be used in the manner described above, orders would be required. Nonetheless, the IIT could not draw definitive conclusions in respect of the requisite degree of certainty as regards the specific chain of command for any specific order issued in this particular incident, including in relation to the involvement in the incident of any States Parties other than the Syrian Arab Republic. Information obtained, however, does indicate that, at this point in the hostilities, use of chlorine as a weapon was delegated by the General Command to operational level commanders—although it is recognised that, even if there is delegation, responsibility always rests with the higher authority.

## **10. SUMMARY OF FACTUAL FINDINGS**

- 10.1 In light of its mandate to identify the perpetrators of the use of chemical weapons in the Syrian Arab Republic by identifying and reporting on all information potentially relevant to the origin of those chemical weapons in the incident under consideration, the IIT concludes that there are reasonable grounds to believe that between 19:10 and 19:40 (UTC +3) on 7 April 2018, during a major military offensive aimed at regaining control of the city of Douma, at least one Mi-8/17 helicopter of the Syrian Arab Air Force, departing from Dumayr airbase and operating under the control of the Tiger Forces, dropped two yellow cylinders which hit two residential buildings in a central area of the city.
- 10.2 At Location 2, the cylinder hit the rooftop floor of a three-storey residential building without fully penetrating it, ruptured, and rapidly released toxic gas—chlorine—in very high concentrations, which rapidly dispersed within the building killing 43 named individuals and affecting dozens more.
- 10.3 At Location 4, the cylinder hit the roof of a three-storey residential building (at that time uninhabited) and broke into the apartment below, landing on a bed after bouncing off the floor. The cylinder ruptured only partially, and started to slowly release chlorine, mildly affecting those who first arrived at the scene.

---

<sup>280</sup> See, in particular, paragraph 1 of Article VII of the Convention, and Note by the Director-General entitled “Compliance with Article VII: Legislation, Cooperation and Legal Assistance” (C-III/DG.1/Rev.1, dated 17 November 1998), in particular paragraphs 2.2, 3.1, and 5.1). States are therefore responsible under international law for use by non-State actors on their territory or in any other place under their jurisdiction in case they fail to investigate and prosecute alleged perpetrators in such instances. See also decision by the Council entitled “Addressing the Threat Posed by the Use of Chemical Weapons by Non-State Actors” (EC-86/DEC.9, dated 13 October 2017).

Annexes:

- Annex 1: Information Management and Other Internal Procedures
- Annex 2: Approach to Obtaining and Securing Information
- Annex 3: Summary of Contacts with Representatives of the Syrian Arab Republic and Other States Parties Relevant to the Current Investigations by the Investigation and Identification Team
- Annex 4: Redacted Paragraphs



## Annex 1

### INFORMATION MANAGEMENT AND OTHER INTERNAL PROCEDURES

1. As explained in the Note by the Technical Secretariat entitled “Work of the Investigation and Identification Team Established by Decision C-SS-4/DEC.3 (dated 27 June 2018)” (EC-92/S/8, dated 3 October 2019), and further detailed in the First Report by the OPCW Investigation and Identification Team Pursuant to Paragraph 10 of Decision C-SS-4/DEC.3 “Addressing the Threat from Chemical Weapons Use” – Ltamenah (Syrian Arab Republic) 24, 25, and 30 March 2017 (hereinafter “First IIT Report”),<sup>281</sup> since the activities of the Investigation and Identification Team (IIT) require vast amounts of information in all its forms to be collected and created, seamless and robust procedures are required to allow for the secure, consistent, and transparent management of such information, from the time of its collection or creation through its ultimate preservation, transfer, or destruction. In setting up these procedures, the IIT took into account confidentiality and security requirements deemed necessary for the storage and use of the information material provided by other entities.
2. Starting from the premise that access to information within the IIT is on a need-to-know basis, effective and secure information handling is considered a key factor for the IIT to fulfil its mandate by: (a) ensuring the safety and security of the IIT’s activities, personnel, and third parties; (b) maintaining the integrity of its records and information; (c) ensuring effective and timely search, analysis, and dissemination of information; and (d) increasing the awareness of confidentiality requirements by promoting correct information handling practices.
3. Established internal procedures related to information management cover all kinds of information material created, obtained, and managed by the IIT, which include both digital and physical material. Provisions are made to ensure the confidentiality of both categories of material in terms of organisational, physical, and information security measures.
4. In particular, and in addition to organisational and physical arrangements, the IIT’s information management systems and its file storage system reside in the IIT Secure Network (ISN), designed and built in compliance with the OPCW Security Critical Network policies and requirements for the protection of OPCW confidential material. The ISN is accessible by designated terminals possessing appropriate security and confidentiality measures, which are “air gapped”, with no external network interface.
5. The IIT’s internal procedures provide for the registry procedure, the structure of the central repository for the IIT’s records and information, access permission based on roles, responsibilities, the repository’s contents, as well as the retention schedule of IIT records and information. Such procedures ensure that the chain of custody of information and the audit trail of records are properly captured, in order to maintain their continued integrity and authenticity. The IIT has further implemented steps to capture and protect results from open-source searches directly related to the identification of perpetrators within the IIT’s mandate. A back-up plan was implemented in order to enhance security.

---

<sup>281</sup> See First IIT Report, especially Annex 1 (Information Management and Other Internal Procedures).

6. The case management system within the ISN aims at supporting investigation activities. This case management system is designed to be conducive to investigation and analysis activities, as well as to ensuring the authenticity and reliability of records. The system, accessible through specific encrypted terminals in the ISN, is designed to allow only the IIT to securely and methodically keep the records and information associated with investigation and analysis activities, add relationships among items, and provide feedback on investigation steps. It allows for a comprehensive account of the chain of custody of each item obtained, including its movement, locations, and transfers. All electronic information collected and generated by the IIT as a result of its investigation activities is to be stored in the information management system. Moreover, the system organises material efficiently for its future transfer to the investigation mechanism established by the United Nations General Assembly in resolution 71/248 (2016) (IIIM), as well as to any relevant investigatory entities established under the auspices of the United Nations, as mandated by paragraph 12 of decision of the Conference of the States Parties entitled “Addressing the Threat from Chemical Weapons Use” (C-SS-4/DEC.3, dated 27 June 2018).
7. Access control functions in this customised case management system allow IIT personnel to access records only with specific predefined permissions (including permissions to create, read, and modify records). The system is further designed to ensure audit trails that cannot be modified or removed. IIT personnel are trained in the use of the system as required and maintain awareness of the necessary security and confidentiality measures taken to protect the information material.

## Annex 2

### APPROACH TO OBTAINING AND SECURING INFORMATION

1. The investigative activities of the Investigation and Identification Team (IIT) on the incident in Douma on 7 April 2018 included gathering and assessing information provided to it by individuals, local entities, States Parties, and other international, regional, and local actors as well as, where applicable and relevant, technical and scientific examinations and analyses to identify the origin of the chemicals used, munition markings and physical characteristics, and technical information and/or extrapolations related to delivery means, such as aircraft flight paths and munition trajectories. The activities further included interviews with alleged victims and other persons who might have witnessed the incident, with experts in the various subjects relevant to the investigation, and evaluation of open-source material.<sup>282</sup> Moreover, the IIT requested gas dispersion modelling to verify the credibility of other information it had obtained related to the release of chlorine gas from the cylinders used in this incident. The IIT further considered computer modelling and cylinder drop trials to model impact velocities of free-falling cylinders similar to the ones used in Douma on 7 April 2018, and assess the damage to replica cylinders/cradles. In fulfilling its mandate, the IIT obtained and analysed information and material from any relevant source in addition to the information already obtained from the OPCW Fact-Finding Mission in Syria (FFM), also in order to determine the relevance, probative value, and reliability of the information, as well as the credibility of the source.
2. The IIT takes specific care to ensure that issues that may arise because of the different languages spoken by the investigators, on the one side, and interviewees, on the other, are properly addressed. Apart from having an interpreter present during interviews, and in addition to summaries of the interviews prepared by the investigators, full transcripts of the interviews are later translated by professionals into English, so as to be able to properly check the original interpretation. A transcript of the interview carried out by the IIT is produced through a process to accurately identify any discrepancy not easily captured when “live” interpretation of an interview is done (consecutively or simultaneously). Moreover, certain interviews are now also conducted directly in the language of the interviewee, with a transcript in English only produced afterwards.
3. For the specific purpose of this report, the IIT reached out to 27 witnesses directly related to this attack (at times reverting to certain individuals to request clarifications of previous statements and to expand on certain matters), including alleged victims.<sup>283</sup> These interviews were considered in conjunction with 39 statements from witnesses previously obtained by the FFM and other entities, thus allowing for a substantial amount of information from a broad variety of sources to be considered.

---

<sup>282</sup> See also Note EC-92/S/8 (dated 3 October 2019) by the Technical Secretariat.

<sup>283</sup> Although the IIT, on certain limited occasions, engaged in remote interviews through secure means (when the security concerns of the interviewee could be properly addressed), it never relied on remote interviews alone in reaching its conclusions, as it deemed the probative value of an in-person interview in the same room as the interviewee to be higher.

4. In relation to other entities willing to provide information, or provide leads for the investigation, the general approach of the IIT has continued to be that of requesting access to information and to the sources of such information that the IIT considered could be obtained from those entities, and to assess them together with the rest of the information already at the IIT's disposal.
5. When entities willing to assist the IIT did not have relevant information directly, but could put the IIT in contact with persons of interest, the IIT proceeded with requesting this type of facilitation on the basis of the following understanding:
  - (a) the IIT would not pay, in any way, fees or other forms of remuneration for the support rendered by these entities;
  - (b) the entity in question would ensure that no person had been unduly influenced or pressured to provide information or extend his/her cooperation for the purpose of the IIT's investigations; and
  - (c) with a view to protecting persons of interest who might be at risk because of their interaction with the IIT, sufficient guarantees would be provided to protect confidentiality as well as the privacy of these persons, including their identification data and statements.
6. Unless specific circumstances dictated otherwise, the IIT treated all information obtained from external entities and individuals as "OPCW Highly Protected", the highest classification category within the OPCW confidentiality regime, and restricted its access on the basis of the need-to-know principle in accordance with the Confidentiality Annex to the Chemical Weapons Convention and the OPCW Policy on Confidentiality.<sup>284</sup>
7. The IIT treated the information collected through a widely shared methodology among investigatory bodies, such as international fact-finding bodies and commissions of inquiry, in particular with regard to the chain of custody of the samples and material.
8. These samples were treated so as to ensure their reliability, including during their transportation to the OPCW Laboratory in the Netherlands and from there to OPCW designated laboratories. This continues to be done in accordance with the Verification Annex to the Chemical Weapons Convention and corresponding applicable internal procedures and practices of the Technical Secretariat.<sup>285</sup>
9. For such material and samples, the chain of custody was maintained and documented by the Technical Secretariat from the moment of collection or receipt. For instance, once in the custody of the Technical Secretariat, samples were treated according to

---

<sup>284</sup> See para. 4.1 of Part V and paras 3.1 to 3.4 of Part VI of the OPCW Policy on Confidentiality (C-I/DEC.13/Rev.2, dated 30 November 2017), as well as subpara. 2(h) of the Confidentiality Annex to the Chemical Weapons Convention.

<sup>285</sup> With specific respect to the storage conditions in the OPCW Laboratory and the degradation of samples to be analysed, see further "Advice on chemical weapons sample stability and storage provided by the Scientific Advisory Board of the Organisation for the Prohibition of Chemical Weapons to increase investigative capabilities worldwide", also available in *Talanta*, vol. 188 (2018), pages 808, 810, and 811.

OPCW procedures to ensure their integrity, as well as their security, preservation, and confidentiality. At the OPCW Laboratory, the samples were prepared for off-site analysis at two OPCW designated laboratories in accordance with paragraph 57 of Part II of the Verification Annex. The sample processing included verification of their identity, i.e., through sample codes, item descriptions, and seal numbers; solvent extraction and/or splitting into fresh primary containers; packaging of sample splits together with positive and negative control samples; and detailed analysis of positive and negative control samples before dispatch. Internal established procedures for splitting, packing, and transportation to the OPCW designated laboratories were applied and all steps of the process were documented.

10. Upon arrival at the OPCW designated laboratories, the identity and seal integrity of the samples are once again verified against the accompanying chain of custody form. All samples (i.e., authentic and control samples) are prepared and analysed in accordance with instructions issued by the OPCW Laboratory. This is in the form of a document setting out the scope of analysis, which also contains the identification data for the samples and their corresponding tamper-proof seal numbers.
11. The OPCW designated laboratories, which operate under a quality system in accordance with International Organization for Standardization/International Electrotechnical Commission standard ISO/IEC 17025, are also obliged to maintain the chain of custody of the samples throughout their processes. All activities performed by the OPCW designated laboratories on behalf of the OPCW must conform to the terms and conditions of the technical arrangements between the Technical Secretariat and the OPCW designated laboratories.
12. Owing to the ongoing conflict(s) occurring in the relevant areas, access by the Technical Secretariat to the sites of incidents shortly after their occurrence was often not possible. Therefore, the IIT has consistently ensured that samples and other material taken by other entities were supported by documents, photographs, video footage, forensic analyses, and/or witness testimony. In order to do this, the IIT reached out to specialists and forensic institutes to provide geolocation and metadata from the image files obtained. This approach has been applied consistently in light of the fact that it is the combination, consistency, and corroboration of all of the information gathered as a whole, rather than single pieces of evidence, which form the basis of the IIT's conclusions.<sup>286</sup>

---

286

See, for instance, Note by the Technical Secretariat S/1654/2018 (dated 20 July 2018), pages 3, 9 to 10, and 21. The IIT further notes that this approach follows the practice of international and domestic investigations in these types of events.

13. The IIT took guidance from practices and principles derived from relevant decisions by the Conference of the States Parties and Technical Secretariat procedures,<sup>287</sup> as well as from the approach of States Parties investigating similar incidents, and applied them *mutatis mutandis*, in full compliance with the Chemical Weapons Convention.
14. Information gathered during the IIT's investigation remains available for transfer to the mechanism established by the United Nations General Assembly in resolution 71/248 (2016) (IIIM) as well as to any relevant investigatory entities established under the auspices of the United Nations, as mandated by paragraph 12 of the Decision of 27 June 2018, and reinforced by paragraph 9 of Executive Council decision entitled "Addressing the Possession and Use of Chemical Weapons by the Syrian Arab Republic" (EC-94/DEC.2, dated 9 July 2020).

---

<sup>287</sup> *Cf.*, among others: Decision by the Conference of the States Parties entitled "Sampling and Analysis during Investigations of Alleged Use of Chemical Weapons" (C-I/DEC.47, dated 16 May 1997); Standard Operating Procedure for Evidence Collection, Documentation, Chain-of-Custody and Preservation During an Investigation of Alleged Use of Chemical Weapons (QDOC/INS/SOP/IAU01), first issued in 2011.

### Annex 3

#### **SUMMARY OF CONTACTS WITH REPRESENTATIVES OF THE SYRIAN ARAB REPUBLIC AND OTHER STATES PARTIES RELEVANT TO THE CURRENT INVESTIGATIONS BY THE INVESTIGATION AND IDENTIFICATION TEAM**

1. In relation to the investigations required under paragraph 10 of decision C-SS-4/DEC.3 “Addressing the Threat from Chemical Weapons Use”, the Technical Secretariat has engaged in continuous and extensive communications aimed at obtaining input from all States Parties, and the Syrian Arab Republic in particular—as detailed in both the First Report by the OPCW Investigation and Identification Team Pursuant to Paragraph 10 of Decision C-SS-4/DEC.3 “Addressing the Threat from Chemical Weapons Use”—Ltamenah (Syrian Arab Republic) 24, 25, and 30 March 2017 (hereinafter, “First IIT Report”)<sup>288</sup> and the Second Report by the OPCW Investigation and Identification Team Pursuant to Paragraph 10 of Decision C-SS-4/DEC.3 “Addressing the Threat from Chemical Weapons Use” – Saraqib (Syrian Arab Republic) 4 February 2018 (hereinafter, “Second IIT Report”).<sup>289</sup>
2. Communications with the authorities of the Syrian Arab Republic between June 2019 (the time the IIT started its activities), April 2020 (when the First IIT Report was issued), April 2021 (when the Second IIT Report was issued), and continued since, have included attempts to consult with those authorities, requests for visits to the Syrian Arab Republic and for meetings with relevant individuals, and invitations to provide the IIT with input on its methodologies, as well as any information on the relevance, probative value, and reliability of information related to the origin of the chemical weapons and useful to identify perpetrators in certain incidents.
3. The authorities of the Syrian Arab Republic did not engage with the IIT, despite: (a) various requests addressed to them by the Technical Secretariat; (b) the obligation by the Syrian Arab Republic to cooperate with the Technical Secretariat under paragraph 7 of Article VII of the Chemical Weapons Convention; and (c) the obligation incumbent on the Syrian Arab Republic, pursuant to United Nations Security Council resolution 2118 (2013), to cooperate fully with the OPCW by providing personnel designated by the OPCW with immediate and unfettered access to any and all sites and individuals that the OPCW has grounds to believe to be of importance for the purpose of its mandate.
4. On 22 December 2021, the Technical Secretariat addressed a note verbale to the Permanent Representation of the Syrian Arab Republic to the OPCW,<sup>290</sup> attaching a note by the IIT which invited the Syrian Arab Republic to, inter alia, submit any concrete information and sources or suggest additional avenues of inquiry in respect of the incident in Douma on 7 April 2018. The note further indicated the IIT’s availability to meet with representatives of the Syrian Arab Republic, at their convenience and at a location of their choosing. The purpose of this meeting would have been to discuss the

---

<sup>288</sup> See First IIT Report, Annex 3 (Summary of Contacts with Representatives of the Syrian Arab Republic Relevant to the Work of the Investigation and Identification Team).

<sup>289</sup> See Second IIT Report, Annex 3 (Summary of Contacts with Representatives of the Syrian Arab Republic Relevant to the Work of the Investigation and Identification Team).

<sup>290</sup> NV/ODG-208/21, 22 December 2021.



progress of the investigation and the provision of other information, including access to locations, which the authorities of the Syrian Arab Republic may be able to facilitate. As at the date of this report, the Technical Secretariat had not received a response from the Syrian Arab Republic to the requests set forth in this note verbale.

5. Also on 22 December 2021, the Technical Secretariat sent a note verbale<sup>291</sup> to the 41 members (i.e. 40 States and the European Union) of the International Partnership against Impunity for the Use of Chemical Weapons (hereinafter “the International Partnership”) via the Permanent Mission of the French Republic, which held the chairpersonship of the Partnership, to seek any concrete information which would have been potentially relevant to establishing the origin of the chemical weapons used in Douma on 7 April 2018 and useful to identify the perpetrators. Bilateral engagement with members of the International Partnership (which are also States Parties to the Chemical Weapons Convention) followed.
6. The IIT also took into due consideration the position expressed at several stages by the Russian Federation on the incident in Douma. Therefore, on 28 January 2022, the Technical Secretariat addressed a note verbale to the Permanent Representation of the Russian Federation to the OPCW<sup>292</sup> requesting any concrete information that would have been potentially relevant to establishing the origin of the chemical weapons used in Douma on 7 April 2018 and useful to identify the perpetrators, including information related to actors that might have had the capabilities to develop, produce, stockpile, and use such weapons. On 15 February 2022, the Permanent Representation of the Russian Federation to the OPCW responded via note verbale to the Technical Secretariat, reiterating its determination that decision C-SS-4/DEC.3 was adopted *ultra vires*, and that therefore paragraph 7 of Article VII of the Convention was not applicable to any activities carried out by the Secretariat in connection with the aforementioned decision.<sup>293</sup> No further elaboration or supporting evidence was provided.

---

<sup>291</sup> NV/ODG-209/21, 22 December 2021.

<sup>292</sup> NV/ODG-223/22, 28 January 2022.

<sup>293</sup> Note Verbale No. 3 from the Permanent Representation of the Russian Federation to the OPCW (dated 15 February 2022).



OPCW

Organisation for the Prohibition of Chemical Weapons

NV/ODG-208/21

The Technical Secretariat (hereinafter referred to as the "Secretariat") of the Organisation for the Prohibition of Chemical Weapons (hereinafter referred to as the "OPCW") presents its compliments to the Permanent Representation of the Syrian Arab Republic of the OPCW.

Reference is made to the work of the Investigation and Identification Team (IIT), established pursuant to paragraph 10 of the Decision adopted by the Conference of the States Parties to the Chemical Weapons Convention on 27 June 2018 (C-SS-4/DEC.3).

Following the issuance of its first two reports (S/1867/2020 dated 8 April 2020, and S/1943/2021 dated 12 April 2021), the IIT is progressing with its investigations and, as mandated by the above-mentioned decision, regularly reaches out to States Parties in order to gather information and conduct investigations and analysis on those incidents under its scope.

As was the case with the letters addressed by the Director-General of the OPCW to the Deputy Foreign Minister for Foreign Affairs and Expatriates of the Syrian Arab Republic dated 19 December 2019, 3 July 2020 and 16 October 2020, a Note is hereby attached seeking the cooperation of the Syrian Arab Republic on these activities as mandated by paragraph 7 of Article VII of the Chemical Weapons Convention.

The Technical Secretariat of the Organisation for the Prohibition of Chemical Weapons avails itself of this opportunity to renew to the Permanent Representation of the Syrian Arab Republic to the OPCW the assurances of its highest consideration.

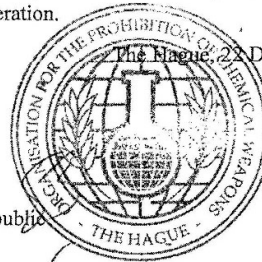

The Hague, 22 December 2021

Permanent Representation of the Syrian Arab Republic  
to the OPCW  
President Kennedylaan 19  
2517 JK The Hague

NOTE

This note follows the previous correspondence related to the work of the OPCW Technical Secretariat through the Investigation and Identification Team (IIT), established pursuant to the Decision of the Conference of the State Parties entitled “Addressing the Threat from Chemical Weapons Use” (C-SS-4/DEC.3, dated 27 June 2018). It further refers to note S/1867/2020 of the Technical Secretariat entitled First Report by the OPCW Investigation and Identification Team Pursuant to Paragraph 10 of Decision C-SS-4/Dec.3 “Addressing the Threat from Chemical Weapons Use” – Ltamenah (Syrian Arab Republic) 24, 25, and 30 March 2017; to note S/1943/2021 entitled Second Report by the OPCW Investigation and Identification Team Pursuant to Paragraph 10 of Decision C-SS-4/Dec.3 “Addressing The Threat From Chemical Weapons Use” - Saraqib (Syrian Arab Republic) – 4 February 2018; and to note S/1918/2020 of the Technical Secretariat entitled “Work Of The Investigation and Identification Team Established Pursuant to Decision C-SS-4/Dec.3 (dated 27 June 2018)”.

Pursuant to paragraph 7 of Article VII of the Convention, each State Party undertakes to cooperate with the Organisation in the exercise of all its functions and in particular to provide assistance to the Secretariat.

As highlighted in the Note of the Technical Secretariat dated 28 June 2019 (EC-91/S/3, para. 10), when a State assumes an obligation in an international agreement, this expresses a legally binding undertaking. Therefore, the Secretariat expects full good-faith cooperation with the IIT from all States Parties, in particular with the provision of relevant information and access to relevant places and persons.

In line with the above, and further to EC-91/S/3, the Director-General, during his opening statement to the Council at its Ninety-First Session, requested all States Parties concerned to provide their full cooperation to the IIT (para. 21 of EC-91/DG.25, dated 9 July 2019). In September 2019, communications requesting assistance were sent to all States Parties, reiterating calls for assistance and specifically requesting information potentially relevant to establish the origin of the chemical weapons used in the nine identified incidents and useful to identify perpetrators.

In his letters to the Deputy Foreign Minister of the Syrian Arab Republic dated 23 October 2019 (L/ODG/221311/19), 19 December 2019 (L/ODG/221960), 3 July 2020 (L/ODG/223647/20) and 16 October 2020 (L/ODG/224348/20), the Director-General specifically called on the Syrian Arab Republic to cooperate with the IIT, and reiterated the Secretariat’s request that it submits any information currently in its possession pertaining to the incidents being investigated.

As the investigative work of the IIT progresses, the Secretariat reiterates once more the IIT’s availability and willingness to receive information related to its mandate, in any setting or format the authorities the Syrian Arab Republic may deem feasible, in particular on the

incidents outlined in Annex 2 of the Note of the Technical Secretariat dated 28 June 2019 (EC-91/S/3) in relation to which the IIT has not yet issued a report.<sup>1</sup>

In light of the above, and with specific reference to the incident that took place in Douma on 7 April 2018,<sup>2</sup> the Secretariat would be grateful for any concrete information the authorities of the Syrian Arab Republic may be able to share potentially relevant to establishing the origin of the chemical weapons used in that instance, and useful to identify the relevant perpetrators. That may include information on delivery methods; background information related to actors that might have the capabilities to develop, product, stockpile and use such weapons; evidence suggesting or contradicting the possible identification of certain actors as the perpetrators; as well as any element related to the relevance, probative value, and reliability of such information and to the credibility of the relevant source(s). The Technical Secretariat would also welcome the opportunity to access, review and discuss the findings of any investigations or scientific or technical studies undertaken by the authorities of the Syrian Arab Republic in relation to the incident.

In particular, the authorities of the Syrian Arab Republic have, at several stages, referenced evidence in their possession pointing to the involvement of different groups and parties in the incident. Therefore, as with other incidents, the Secretariat would be grateful for any concrete information and sources (including videos, photographs, witness statements and GPS coordinates) that the authorities of the Syrian Arab Republic may have in their possession, supporting these statements or suggesting additional avenues of inquiry, including specific details on relevant subjects, command and control structures and locations of interest.

The Secretariat has also taken note of the Syrian Arab Republic's position that not all the witnesses made available by it in relation to the incident were interviewed by the OPCW Fact-Finding Mission. The Secretariat hereby reiterates the IIT's willingness and availability to conduct any interviews with witnesses present at the time and site of the incident that the Syrian Arab Republic may be in the position to facilitate.

In addition, the Secretariat would greatly appreciate the Syrian Arab Republic's cooperation with regard to the following:

- Provision of any available certificates (e.g. death, medical, burial) relating to fatalities buried in Douma as a result of the incident of 7 April 2018;
- Provision of flight logs from the Dumayr Airbase on and around 7 April 2018, as well as of any indication as to the operational height/range of altitudes of the Syrian Air Force military aircrafts flying over Douma on 7 April 2018;

As the examination of the available information concerning the use of chemical weapons in the aforementioned incident continues, the Secretariat would like to once again reiterate the value of the IIT engaging with representatives of the Syrian Arab Republic, at latter's convenience and at a location of their choosing, to discuss the progress of its investigation as well as the

---

<sup>1</sup> Al-Tamanah (12 and 18 April 2014), Kafri-Zita (18 April 2014), Marea (1 September 2015) and Douma (7 April 2018).

<sup>2</sup> Ref: Note by the Technical Secretariat Report of the OPCW Fact-Finding Mission in Syria Regarding the Incident of Alleged Use of Toxic Chemicals as a Weapon in Douma, Syrian Arab Republic, On 7 April 2018, S/1731/2019 (dated 1 March 2019).

provision of any information and access to relevant locations that the authorities of the Syrian Arab Republic may be able to facilitate.



OPCW

Organisation for the Prohibition of Chemical Weapons

NV/ODG-209/21

The Technical Secretariat (hereinafter referred to as the “Secretariat”) of the Organisation for the Prohibition of Chemical Weapons (hereinafter referred to as the “OPCW”) presents its compliments to the Permanent Representation of French Republic to the OPCW.

Further to its establishment as per Decision “Addressing the Threat from Chemical Weapons Use”, C-SS-4/DEC.3 (dated 27 June 2018) of the Conference of State Parties to the Convention on Chemical Weapons (hereinafter “the Convention”), the Investigation and Identification Team (IIT) has been investigating the incidents outlined in Annex 2 of the Note of the Technical Secretariat dated 28 June 2019 (EC-91/S/3).

Pursuant to paragraph 7 of Article VII of the Convention, each State Party undertakes to cooperate with the Organisation in the exercise of all its functions and in particular to provide assistance to the Secretariat. Upon that legal basis, the IIT expects – and relies upon – full good-faith cooperation from all States Parties, in particular with the provision of relevant information and access to relevant places and persons.

Further to EC-91/S/3, the Director-General, during his opening statement to the Council at its Ninety-First Session, requested all States Parties concerned to provide their full cooperation to the IIT (para. 21 of EC-91/DG.25, dated 9 July 2019). In September 2019, communications requesting assistance were sent to all States Parties, reiterating calls for assistance and specifically requesting information potentially relevant to establish the origin of the chemical weapons used in the nine identified incidents within its purview and useful to identify perpetrators.

Since its establishment, the International Partnership against Impunity for the Use of Chemical Weapons (hereinafter “the International Partnership”) – which France is presently chairing – has played a key role in fostering support to the mandate and work of the IIT, for which the Secretariat remains grateful.

In light of the above, with specific reference to the incident that took place in Douma on 7 April 2018, the Secretariat would be grateful for any concrete information (in the form of photographs, videos, satellite imagery, technical assessments, intelligence information or other evidence) the members of the International Partnership may be able to share that would be potentially relevant to establishing the origin of the chemical weapons used in that instance and useful to identify the relevant perpetrators. This may include information on delivery methods; background information related to actors that might have the capabilities to develop, product, stockpile and use such weapons; evidence suggesting or contradicting the possible identification of certain actors as the perpetrators; as well as any element related to the relevance, probative value, and reliability of such information and to the credibility of the relevant source(s).

Permanent Representation of the French Republic  
to the OPCW  
Anna Paulownastraat 76  
2518 BJ The Hague

The International Partnership's cooperation with the Secretariat will be highly appreciated. The Coordinator of the IIT remains available for any clarification you might deem necessary in this respect.

The Technical Secretariat of the Organisation for the Prohibition of Chemical Weapons avails itself of this opportunity to renew to the Permanent Representation of the French Republic to the OPCW the assurances of its highest consideration.

The Hague, 22 December 2021







OPCW

Organisation for the Prohibition of Chemical Weapons

NV/ODG-223/22

The Technical Secretariat (hereinafter referred to as the “Secretariat”) of the Organisation for the Prohibition of Chemical Weapons (hereinafter referred to as the “OPCW”) presents its compliments to the Permanent Representation of the Russian Federation of the OPCW. Reference is made to the work of the Investigation and Identification Team (IIT), established pursuant to paragraph 10 of the Decision adopted by the Conference of the States Parties to the Chemical Weapons Convention (hereinafter “the Convention”) on 27 June 2018 (C-SS-4/DEC.3).

Further to its establishment, the IIT has been investigating the incidents outlined in Annex 2 of the Note of the Technical Secretariat dated 28 June 2019 (EC-91/S/3).

Following the issuance of its first two reports (S/1867/2020 dated 8 April 2020, and S/1943/2021 dated 12 April 2021), the IIT is progressing with its investigations and, as mandated by the above-mentioned decision, regularly reaches out to States Parties in order to gather information and conduct investigations and analysis on those incidents under its scope.

Pursuant to paragraph 7 of Article VII of the Convention, each State Party undertakes to cooperate with the Organisation in the exercise of all its functions and in particular to provide assistance to the Secretariat.

As highlighted in the Note of the Technical Secretariat dated 28 June 2019 (EC-91/S/3, para. 10), when a State assumes an obligation in an international agreement, this expresses a legally binding undertaking. Therefore, the Secretariat expects full cooperation from all States Parties, in particular with the provision of relevant information.

As further emphasized in the Note of the Technical Secretariat EC-92/S/8 dated 3 October 2019 (para. 16), further to EC-91/S/3, the Director-General, during his opening statement to the Council at its Ninety-First Session, requested all States Parties concerned to provide their full cooperation to the IIT (para. 21 of EC-91/DG.25, dated 9 July 2019). In September 2019, communications requesting assistance were sent to all States Parties, reiterating calls for assistance and specifically requesting information potentially relevant to establish the origin of the chemical weapons used in the nine identified incidents and useful to identify perpetrators.

Permanent Representation of the Russian Federation  
to the OPCW  
Andries Bickerweg 2  
2517 JP The Hague

In light of the above, with specific reference to the incident that took place in Douma on 7 April 2018, the Secretariat would be grateful for any concrete information the Russian Federation may be able to share that would be potentially relevant to establishing the origin of the chemical weapons used in that instance and useful to identify the relevant perpetrators. This may include information on delivery methods; background information related to actors that might have the capabilities to develop, product, stockpile and use such weapons; evidence suggesting or contradicting the possible identification of certain actors as the perpetrators; as well as any element related to the relevance, probative value, and reliability of such information and to the credibility of the relevant source(s).

The Russian Federation's cooperation with the Secretariat will be highly appreciated. The Coordinator of the IIT remains available for any clarification you might deem necessary in this respect.

The Technical Secretariat of the Organisation for the Prohibition of Chemical Weapons avails itself of this opportunity to renew to the Permanent Representation of the Russian Federation to the OPCW the assurances of its highest consideration.

The Hague, 28 January 2022



CMS Reg. #



**ПОСТОЯННОЕ ПРЕДСТАВИТЕЛЬСТВО  
РОССИЙСКОЙ ФЕДЕРАЦИИ  
ПРИ ОРГАНИЗАЦИИ ПО ЗАПРЕЩЕНИЮ  
ХИМИЧЕСКОГО ОРУЖИЯ**

**PERMANENT REPRESENTATION  
OF THE RUSSIAN FEDERATION  
TO THE ORGANISATION FOR THE PROHIBITION  
OF CHEMICAL WEAPONS**

№ 3

The Permanent Representation of the Russian Federation to the Organisation for the Prohibition of Chemical Weapons (OPCW) presents its compliments to the Technical Secretariat (hereinafter referred to as the “Secretariat”) of the OPCW and, with reference to its Note Verbale NV/ODG-223/22, dated 28 January 2022, has the honour to state the following.

The Russian Federation continues to proceed from its determination stipulated in Note Verbale 530, dated 21 March 2019, that the Decision of the Conference of States Parties to the Chemical Weapons Convention (hereinafter the “Convention”) on 27 June 2018 (C-SS-4/DEC.3) was adopted *ultra vires* and is not in conformity with the letter and spirit of the Convention. Hence it is a resolute position of the Russian Federation that the States Parties do not have obligations to provide assistance to the Secretariat as paragraph 7 of Article VII of the Convention is not applicable to any activities carried out by the Secretariat in connection with the aforementioned decision.

**TECHNICAL SECRETARIAT  
OF THE ORGANISATION FOR THE PROHIBITION  
OF CHEMICAL WEAPONS**

**The Hague**

The Permanent Representation reminds the Secretariat of its Communications EC-94/NAT.17, dated 19 June 2020 and EC-97/NAT.8, dated 5 July 2021 with a detailed assessment of the gaps, inconsistencies and discrepancies contained in documents S/1867/2020 and S/1943/2021. The Secretariat is yet to provide any formal reply to the issues raised by the Russian Federation.

The Permanent Representation further reminds the Secretariat of its numerous communications in connection with the “Report of the Fact-Finding Mission regarding the incident of alleged use of toxic chemicals as a weapon in Douma, Syrian Arab Republic, on 7 April 2018”, in particular Note 759, dated 26 April 2019 with detailed information on the irregularities in document S/1731/2019. The Russian Federation is still awaiting clarity on the concerns stipulated in the aforementioned Note.

The Permanent Representation would like to use this opportunity to request that the Secretariat refrain from any further attempts to deliberately misrepresent the official communications of the Russian Federation, as it was the case during the 8785th meeting of the United Nations Security Council on 3 June 2021.

The Permanent Representation avails itself of this opportunity to renew to the Technical Secretariat the assurances of its highest consideration.



*SH*

The Hague, « 15 » February 2022

**Annex 4**

**REDACTED PARAGRAPHS**

This Annex has been classified as “OPCW Highly Protected” and is available to all States Parties in document IIT/HP/XXX, dated XX January 2023.

**--- 0 ---**